

FLOE DOCK BENCH ARMREST
P/N 510-41610-00
ASSEMBLY INSTRUCTIONS

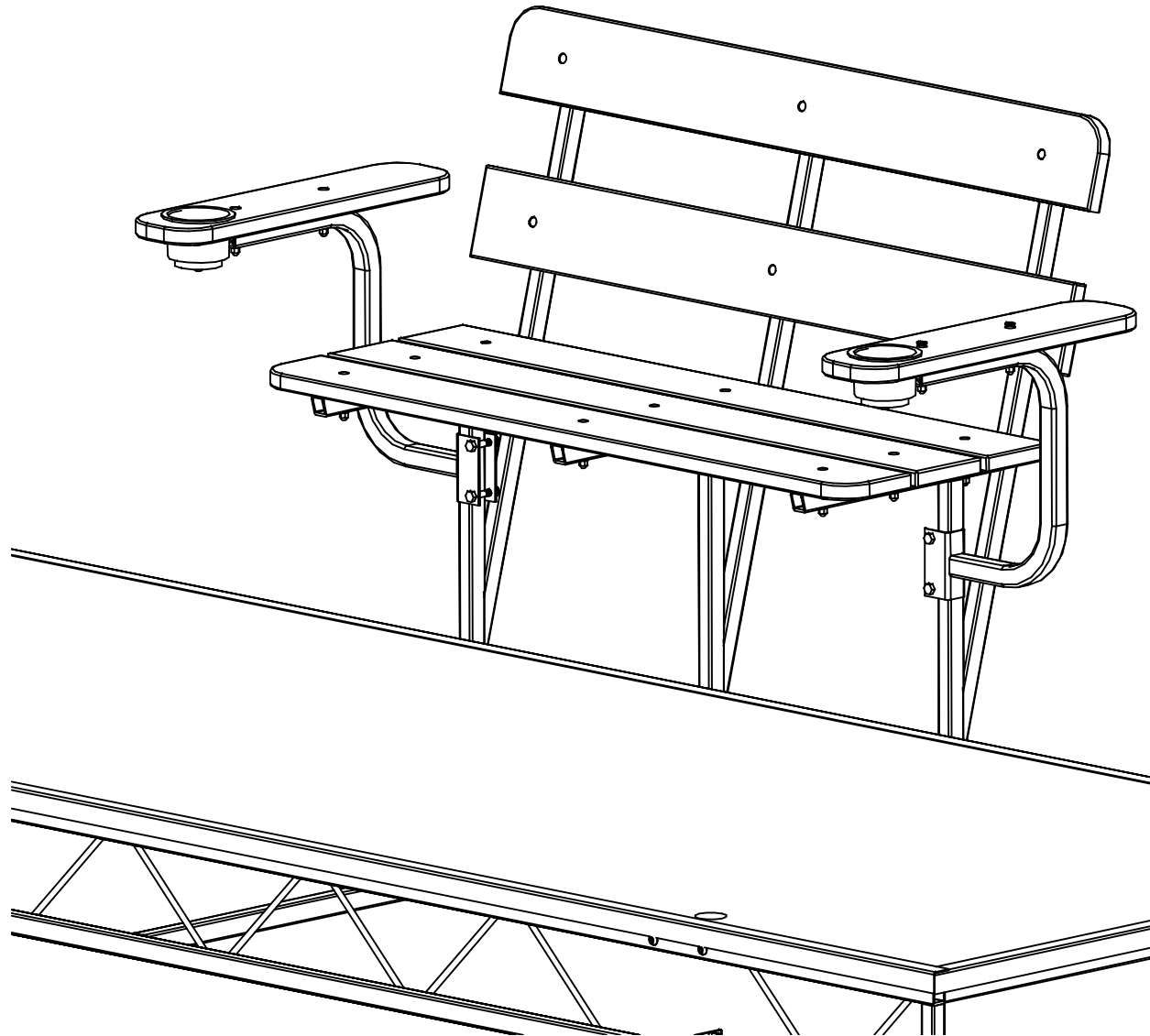
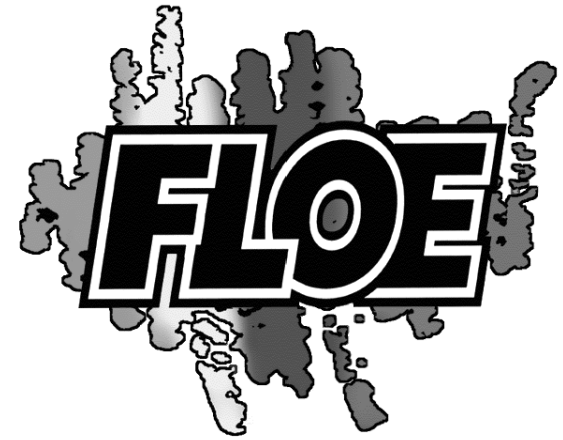

Tools Required

- (2) 9/16" wrenches or sockets
- (1) 7/16" wrench or socket
- (1) Torque wrench

BENCH ARMREST EXPLODED VIEW

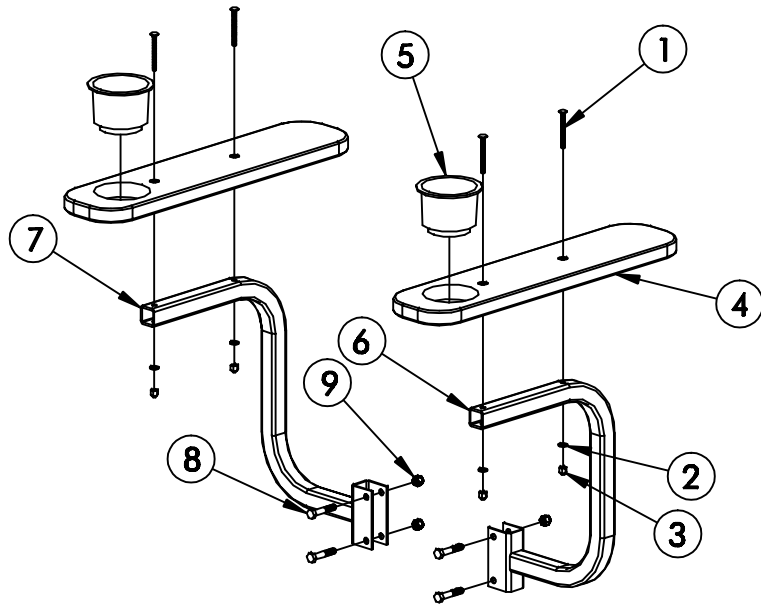

NO.	PART NO.	QTY.	DESCRIPTION
1	001-74424-00	4	CB, 1/4-20 x2 1/2" SS
2	001-71063-00	4	1/4" SW, SS 8-18
3	001-70960-00	4	NUT, ACORN 1/4-20 SS
4	011-01710-00	2	ARMREST, COMPOSITE
5	010-00024-00	2	CUPHOLDER, ARMREST
6	110-00162-00	1	WELDMENT, ARMREST - (LEFT)
7	110-11161-00	1	WELDMENT, ARMREST - (RIGHT)
8	001-70111-00	4	HHCS, 3/8-16 x 2" 18-8 SS
9	001-76071-00	4	NUT, NYLOCK 3/8-16 ALUMINUM

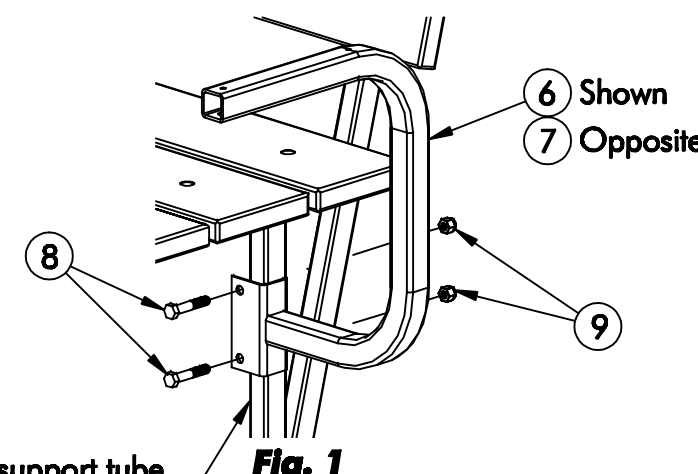

STEP 1

- Place the armrest weldments (Items 6 & 7) toward the top of the bench support tube. Insert the (4) 3/8" x 2" bolts (Item 8) through the holes in the mounting brackets. Add the (4) 3/8" nylock nuts (Item 9), and tighten just enough to hold the armrests in place. See Fig. 1.

STEP 2

- Insert the (4) CB 1/4-20 x 2 1/2" (Item 1) through the armrest (Item 4) from the counterbored side and through the armrest weldments (Item 6 & 7). Install the (4) 1/4" SW, & (4) acorn nuts 1/4-20. See Fig. 2. Torque to 10 ft./lbs. **CAUTION DO NOT OVERTIGHTEN !!!!!**

STEP 3

- Adjust the armrests up or down to the desired location. Torque the (4) 3/8" x 2" bolts (Item 8) & (4) 3/8" nylock nuts to 20 ft./lbs. See Fig. 1. Insert the (2) armrest cupholders (Item 5) into the armrest (Item 4). See Fig. 2.

