

FLOE DOCK MOUNTED ADJUSTABLE BOW STOP QUICK ATTACH SECTIONAL MOUNTING BRACKETS

ASSEMBLY INSTRUCTIONS

KIT P/N 510-02582-01

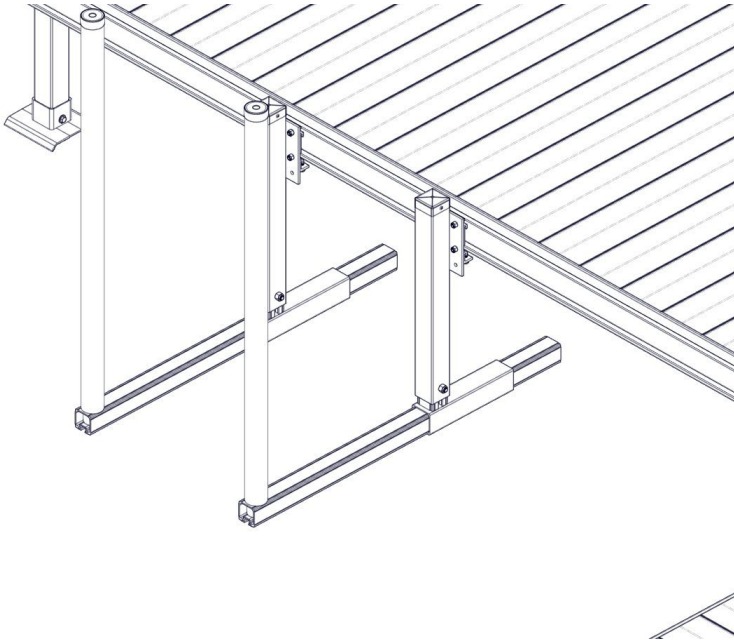

TOOLS REQUIRED

- (2) 9/16" SOCKETS/WRENCHES
- 3/4" SOCKET/WRENCH
- TAPE MEASURE
- TORQUE WRENCH
- MARKER

* DOCK & LEGS NOT INCLUDED

IMPORTANT NOTE:

CAUTION MUST BE USED WHEN PARKING A BOAT WITH THIS KIT INSTALLED. BOATS SHOULD BE DRIFTED INTO FINAL POSITION ON BOAT LIFT. FAILURE TO DO SO WILL RESULT IN DAMAGE TO BOAT, BOAT LIFT, AND/OR LIFT ACCESSORIES.

NOTE:

ADJUSTABLE BOW STOP IS SOLD SEPARATELY (KIT P/N 511-00008-01). REFER TO INSTRUCTIONS INCLUDED WITH THE KIT FOR ASSEMBLY.

BILL OF MATERIALS/EXPLODED VIEW

P/N 510-02582-01		KIT, QA SECTIONAL ADJ. BOW STOP BRACKETS	
NO.	PART NUMBER	DESCRIPTION	QTY
1	001-70105-00	HHCS, 3/8-16 X 1" 18-8 SS	12
2	001-76071-00	NUT, NYLOCK 3/8-16 ALUM.	8
3	002-00149-01	BRACKET, QA SCTN'L FURNITURE - 5.25"	2

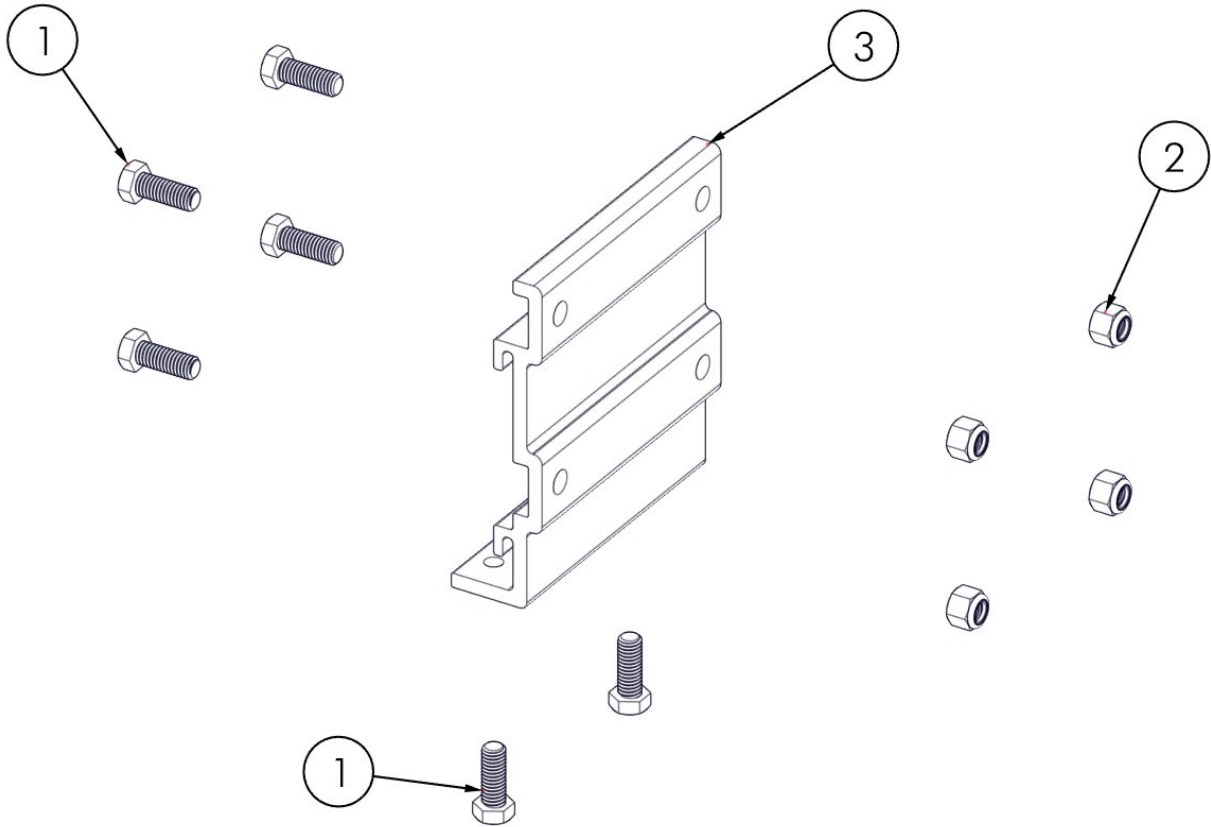

ASSEMBLY

PLACE (4) 3/8" X 1" BOLTS INTO EACH BRACKET AND INTO THE BOW STOP UPRIGHT (FIGURE 1.1) AND ATTACH USING (4) 3/8" NYLOCK NUTS (FIGURE 1.2).

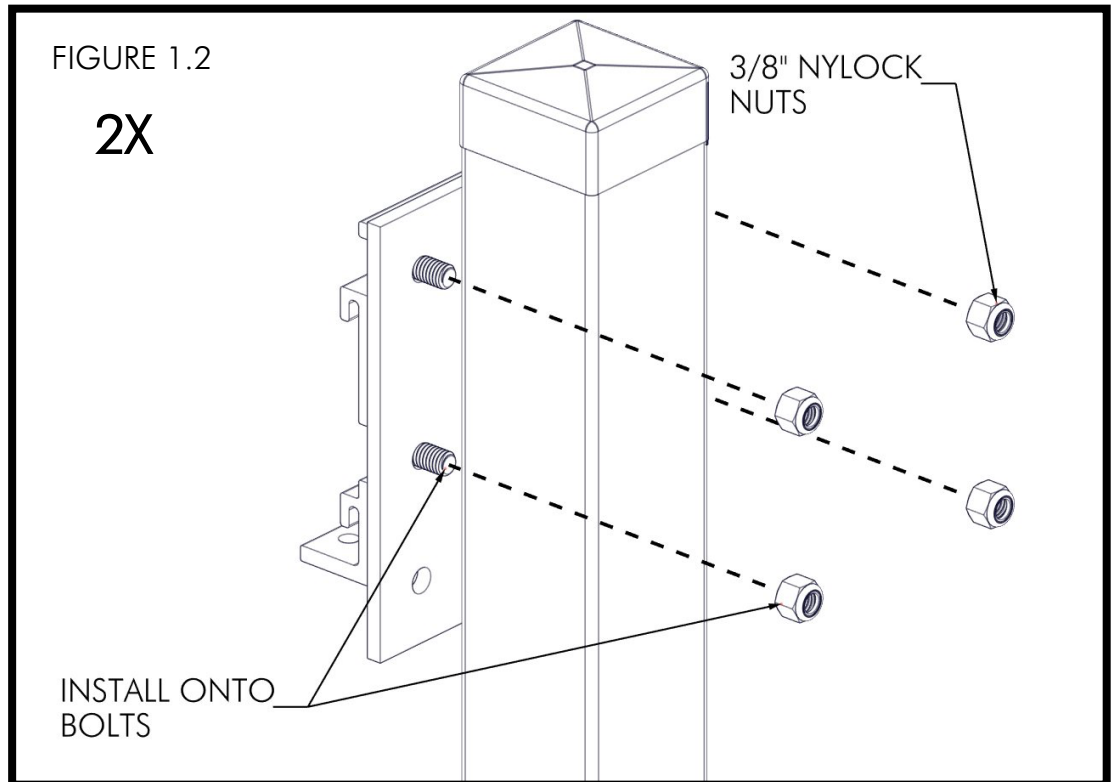
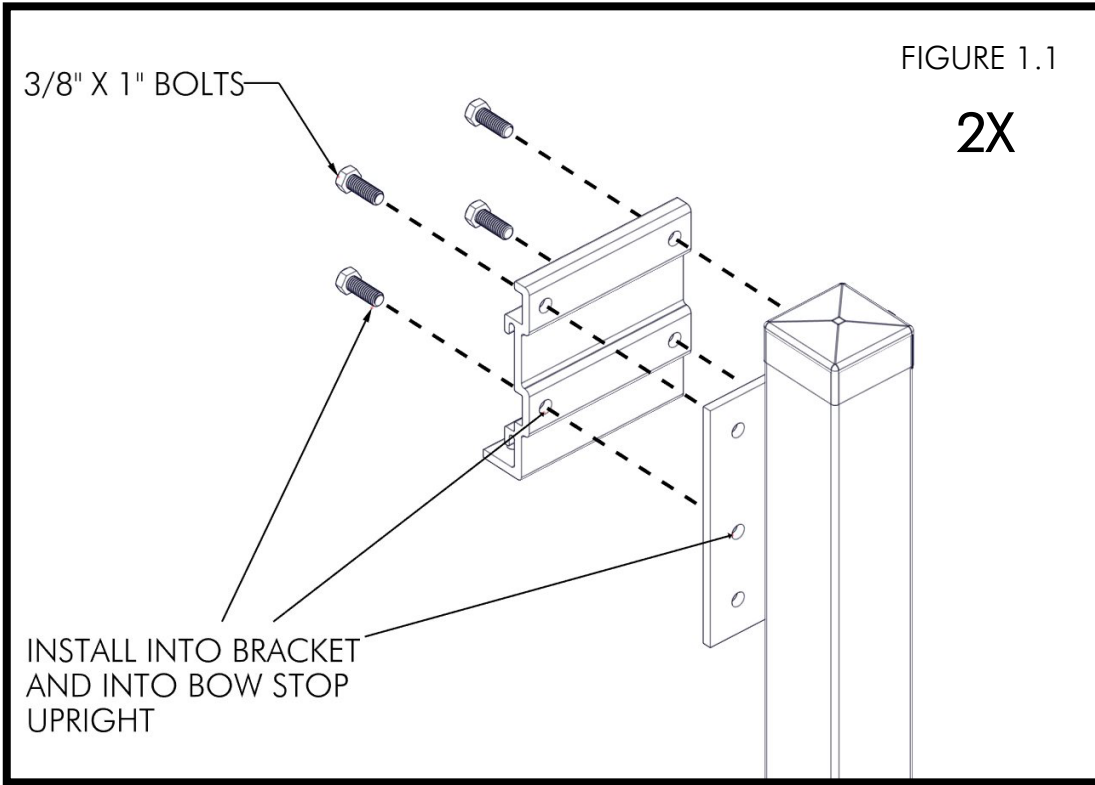

TORQUE NUTS TO 20 FT-LB (FIGURE 1.3). START (2) 3/8" X 1" BOLTS INTO THE BOTTOM OF EACH BRACKET, BUT DO NOT TIGHTEN (FIGURE 1.4).

FIGURE 1.3

2X

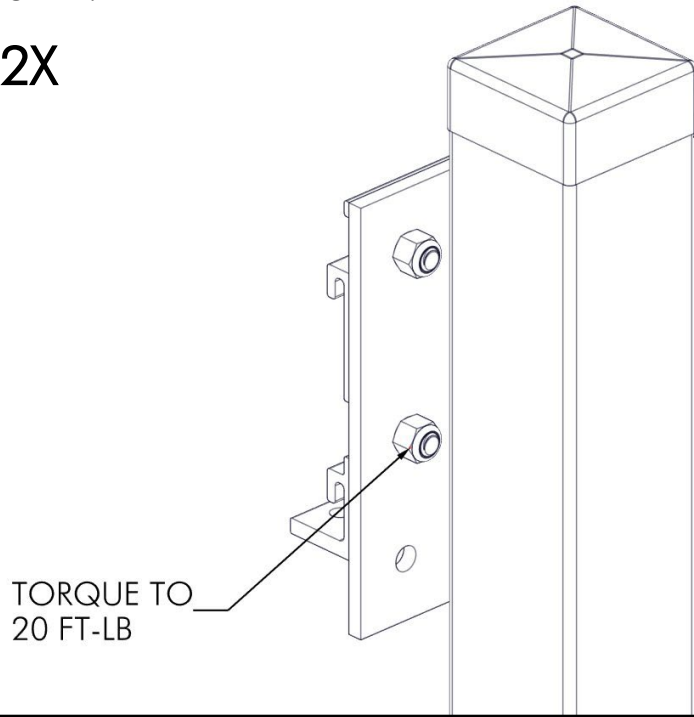
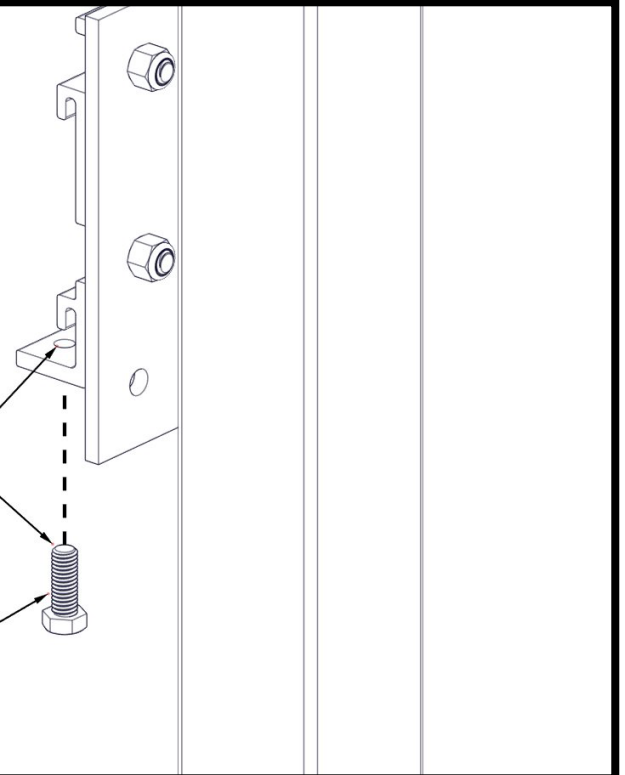

FIGURE 1.4

2X

INSTALL INTO
BOTTOM OF BRACKET

3/8" X 1" BOLTS



INSTALL THE BRACKET WITH BOW STOP UPRIGHT ONTO THE DOCK SIDE IN THE DESIRED LOCATION (FIGURE 1.5 & 1.6). USING THE MEASUREMENT FROM THE PRE-INSTALLATION STEP OF THE BOW STOP ASSEMBLY INSTRUCTIONS (WITH 511-00008-01), SET THE WIDTH OF THE BRACKETS. **NOTE: THE PVC UPRIGHTS SHOULD NOT BE BENT FORWARD OR TOWARDS THE SIDES OF THE HULL** (FIGURE 1.6).

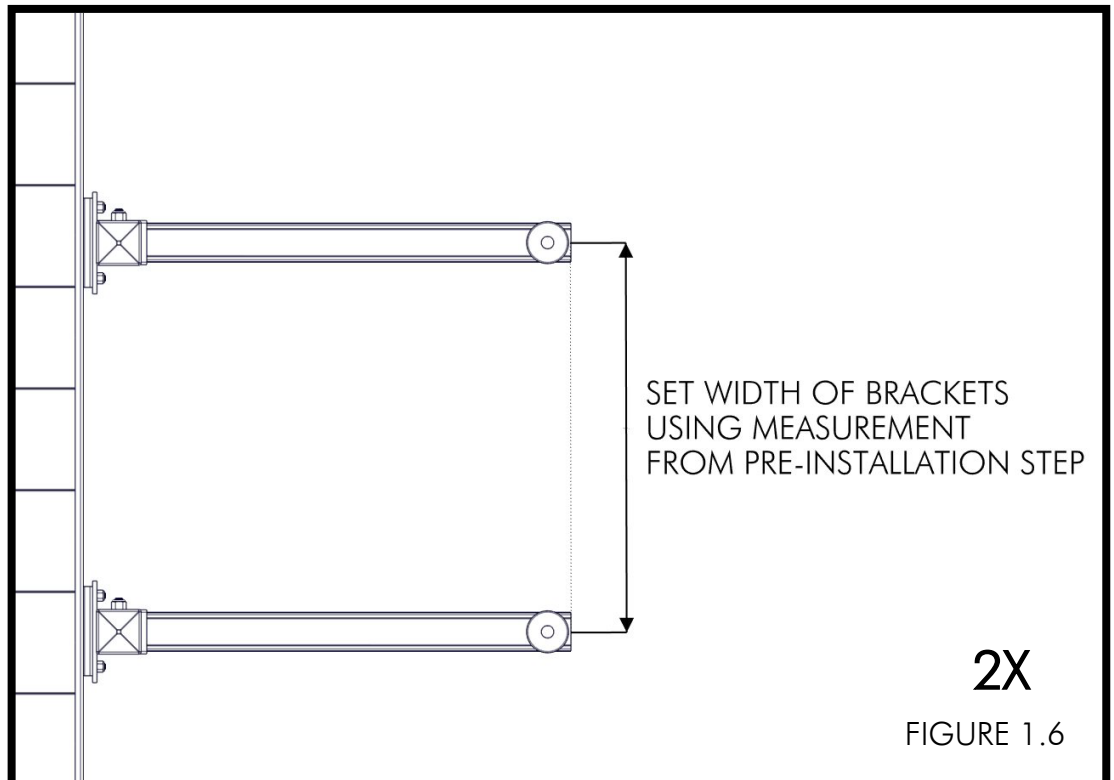
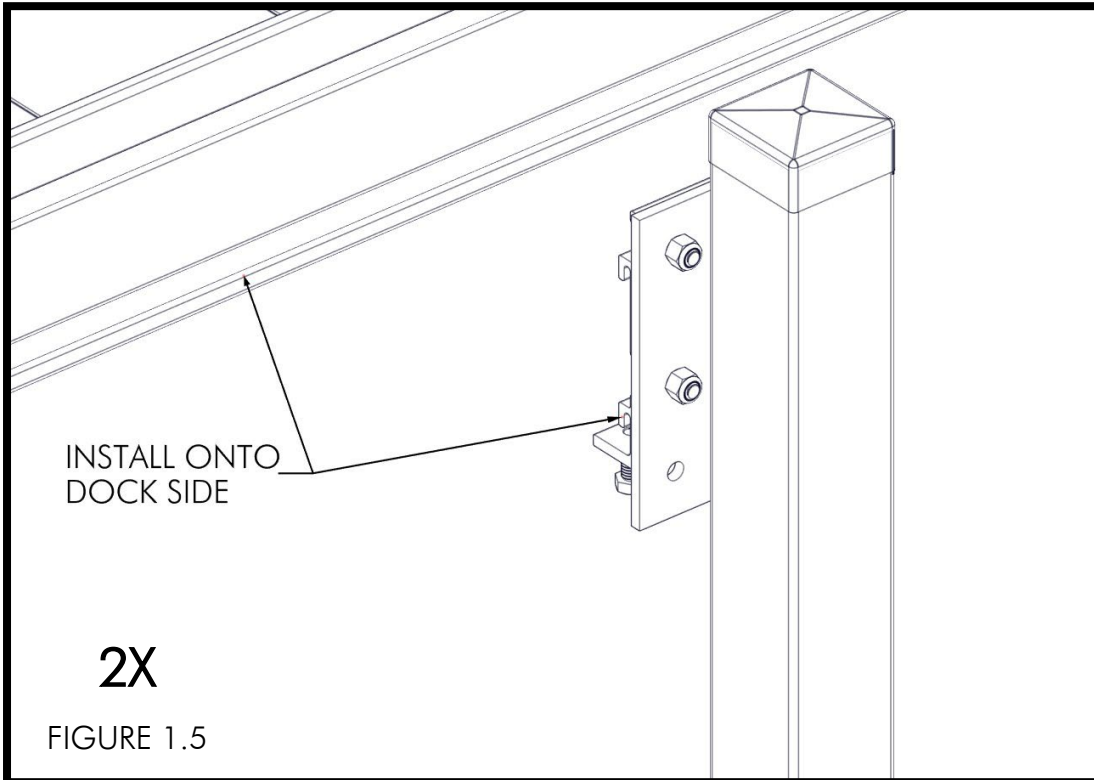

TORQUE BOLTS TO 6 FT-LBS MAXIMUM (FIGURE 1.7).

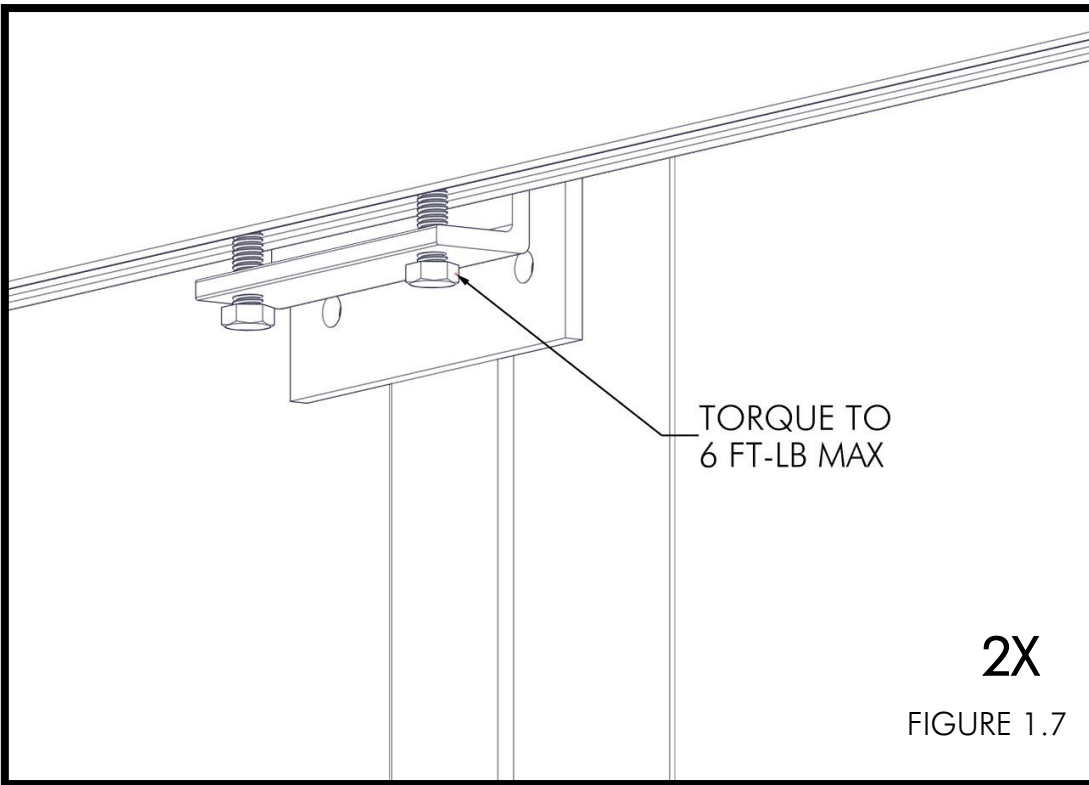

PARK BOAT ON LIFT AND SET THE POSITION OF BOW STOP UPRIGHTS BY SLIDING THE UPRIGHTS UNTIL THEY CONTACT THE BOAT. THE PVC UPRIGHTS SHOULD NOT BE BENT FORWARD OR TOWARDS THE SIDES OF THE HULL AND THE TOP OF THE TUBE SHOULD BE 6-8 INCHES ABOVE THE RUB RAIL WHEN THE BOAT IS FLOATING INSIDE OF THE LIFT. TORQUE 1/2" NYLOCK NUTS TO 20 FT-LB (FIGURES 1.8 & 1.9).

