

FLOE QUICK ATTACH ROLL IN X-DEEP & XX-DEEP WHEEL KIT

ASSEMBLY INSTRUCTIONS AND OWNERS MANUAL

4', 5', 6' & 8' WIDE DOCK SECTIONS

KIT P/N 510-27500-00, 510-27510-00, 510-27600-00, 510-27610-00

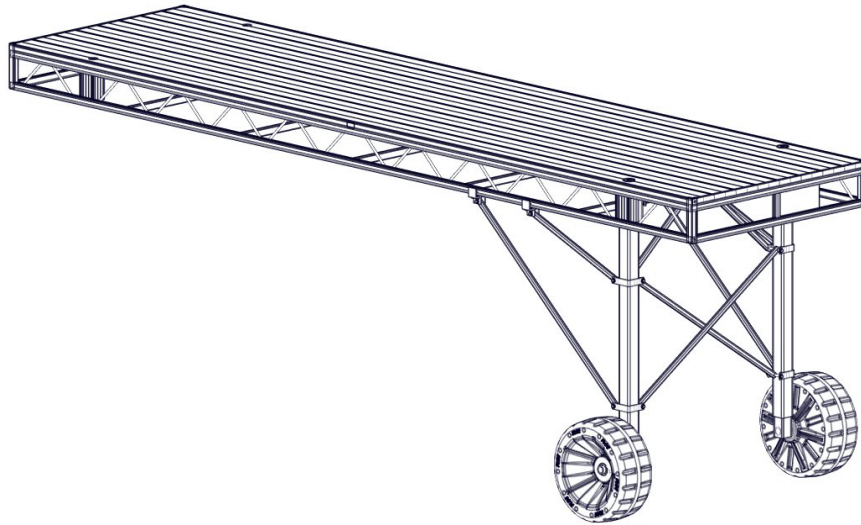

*DOCK NOT INCLUDED

NOTE:

FOR USE IN APPROXIMATELY
49" - 89" OF WATER (X-DEEP)
68" - 108" OF WATER (XX-DEEP)

WE RECOMMEND THAT THE
LOWER DOCK FRAME IS A
MINIMUM OF 8" ABOVE THE
WATER WHEN PROPERLY
ADJUSTED. HOWEVER, IF YOU
HAVE HIGH WAVE
CONDITIONS THAT
COMMONLY EXCEED 15", WE
RECOMMEND THAT YOU RAISE
YOUR DOCK ACCORDINGLY.

TOOLS REQUIRED

- (2) 9/16" SOCKETS/WRENCHES
- 3/4" WRENCH/SOCKET
- CORDLESS DRILL WITH SOCKET ADAPTER & 1-1/8" SOCKET OR FLOE SPEED WRENCH
- TORQUE WRENCH
- TAPE MEASURE
- LEVEL
- BLOCKING MATERIAL



WARNING



NEVER ADJUST YOUR DOCK LEGS WITH AN IMPACT WRENCH. NEVER ADJUST YOUR DOCK LEGS WITH MORE THAN 15 FT-LBS OF FORCE. APPLYING TOO MUCH FORCE TO YOUR DOCK LEGS WILL DAMAGE THE MECHANISM.

**DOCK OWNERS MANUAL IS LOCATED ONLINE AT
FLOEINTL.COM/MANUALS-AND-INFORMATION**

LEG ADJUSTMENT

NOTE:

FOR USE IN APPROXIMATELY 49"-89" (X-DEEP) & 68"-108" (XX-DEEP) OF WATER.

WE RECOMMEND THAT THE LOWER DOCK FRAME IS A MINIMUM OF 8" ABOVE THE WATER WHEN PROPERLY ADJUSTED. HOWEVER, IF YOU HAVE HIGH WAVE CONDITIONS THAT COMMONLY EXCEED 15", WE RECOMMEND THAT YOU RAISE YOUR DOCK ACCORDINGLY.



WARNING



NEVER ADJUST YOUR DOCK LEGS WITH AN IMPACT WRENCH. NEVER ADJUST YOUR DOCK LEGS WITH MORE THAN 15 FT-LBS OF FORCE. APPLYING TOO MUCH FORCE TO YOUR DOCK LEGS WILL DAMAGE THE MECHANISM.

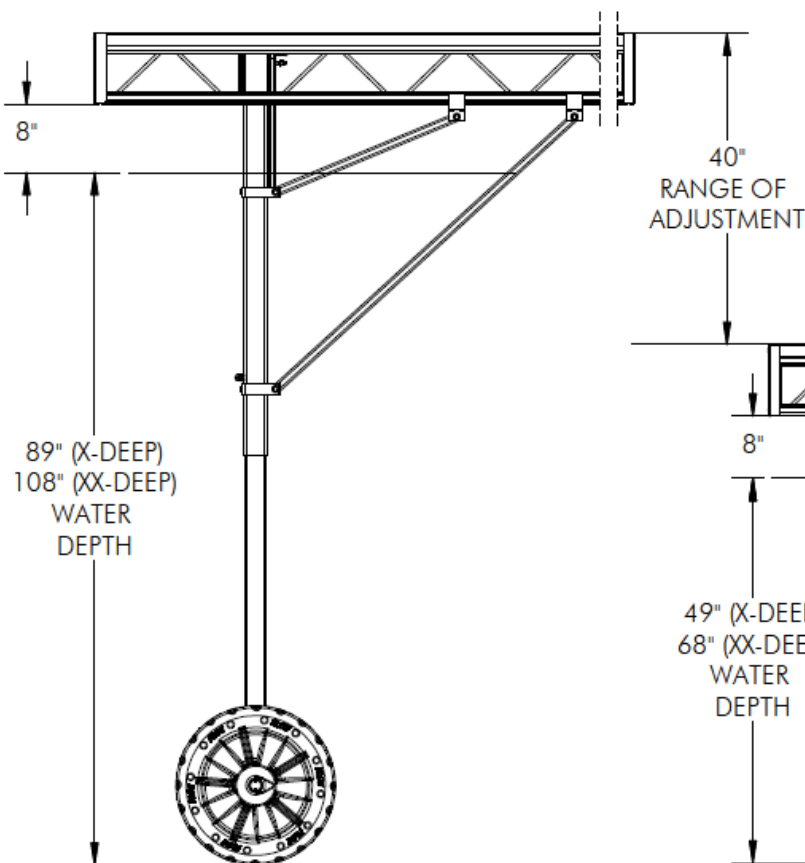

X-DEEP & XX-DEEP
WHEEL KIT
FULLY EXTENDED

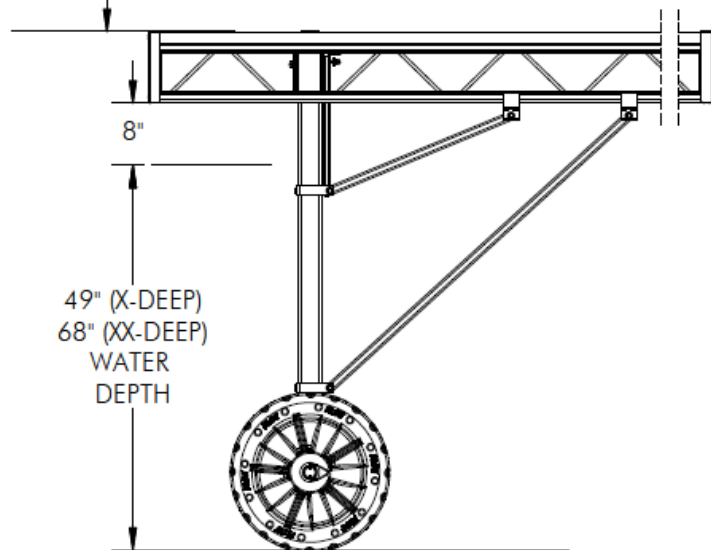

X-DEEP & XX-DEEP
WHEEL KIT
FULLY COLLAPSED

BILL OF MATERIALS

P/N 510-27500-00		WHEEL KIT, QA X-DEEP (PAIR) BZ	
P/N 510-27600-00		WHEEL KIT, QA XX-DEEP (PAIR) BZ	
NUMBER	PART NUMBER	QTY.	DESCRIPTION
1	001-02326-00	1	FASTENERS, QA ROLL-IN X-D/XX-D W/K PAIR
2	002-00064-00	4	BRACKET, W/K BRACE 1.125"
3	002-00285-00	4	BRACKET, QA DOCK SIDE BRACE
4	002-00291-00	2	QUICK CONNECT, QA ROLL-IN – 2"
5	002-02087-00	2	BRACE, WHEEL KIT – 46.5"
6	002-02088-00	4	TUBE, .875" X 1.063" X 26"
7	002-02089-00	2	BRACE, WHEEL KIT 52.75"
8	110-00223-02	2	ASS'Y, LEG W/K (X-DEEP) BRONZE
	110-00226-01	2	ASS'Y, LEG W/K (XX-DEEP) BRONZE

P/N 001-02326-00		FASTENERS, QA ROLL-IN X-D/XX-D W/K PAIR	
NUMBER	PART NUMBER	QTY.	DESCRIPTION
1A	001-26728-00	2	CLIP, STAINLESS STEEL SPINDLE
1B	001-70105-00	10	HHCS, 3/8-16 X 1" SS
1C	001-70110-00	8	HHCS, 3/8-16 X 1-3/4" 18-8 SS
1D	001-70114-00	2	HHCS, 3/8-16 X 2-3/4" 18-8 SS
1E	001-70119-00	2	HHCS, 3/8-16 X 4" 18-8 SS
1F	001-70123-00	2	HHCS, 3/8-16 X 5" 18-8 SS
1G	001-70205-00	2	HHCS, 1/2-13 X 1" SS 18-8
1H	001-71017-00	26	FLAT WASHER, 3/8" SAE SS 18-8
1I	001-76349-00	13	NUT, 3/8-16 ALUM.
1J	001-76350-00	2	NUT, 1/2-13 ALUM.
1K	010-00020-00	2	WASHER, 2.5" O.D. X 1.75" I.D.

SOLD SEPARATELY



Plastic dock wheels
 Drilled 010-06001-00
 Floating 010-06002-00

Sand pads
 P/N 510-17000-00

NOTE:
 EXTRA HARDWARE IS
 INCLUDED THAT
 MAY NOT BE USED
 IN SOME
 APPLICATIONS.

EXPLODED VIEW

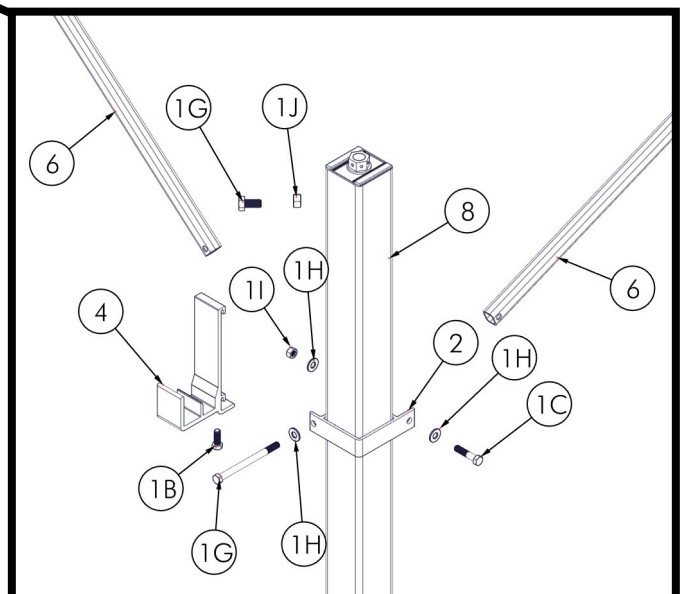
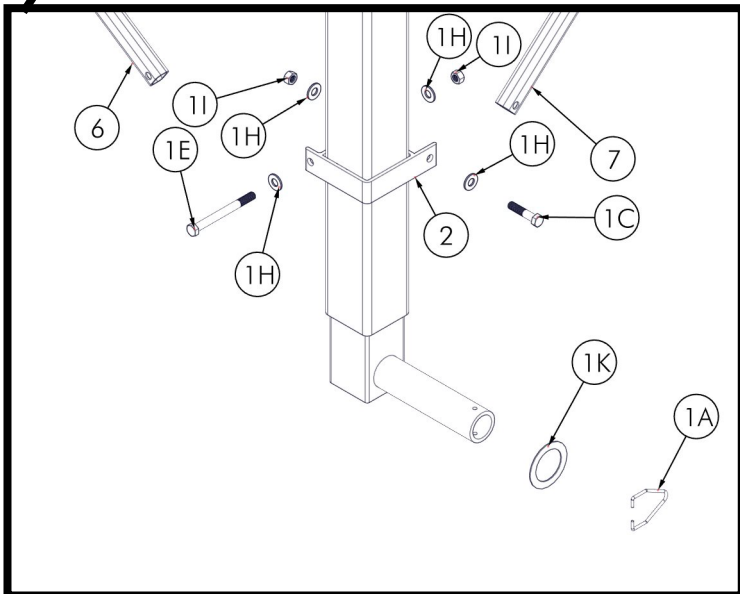
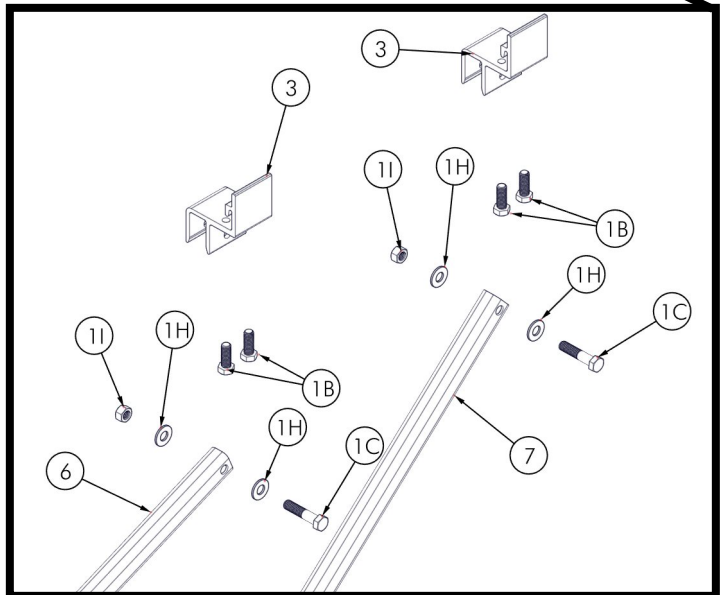
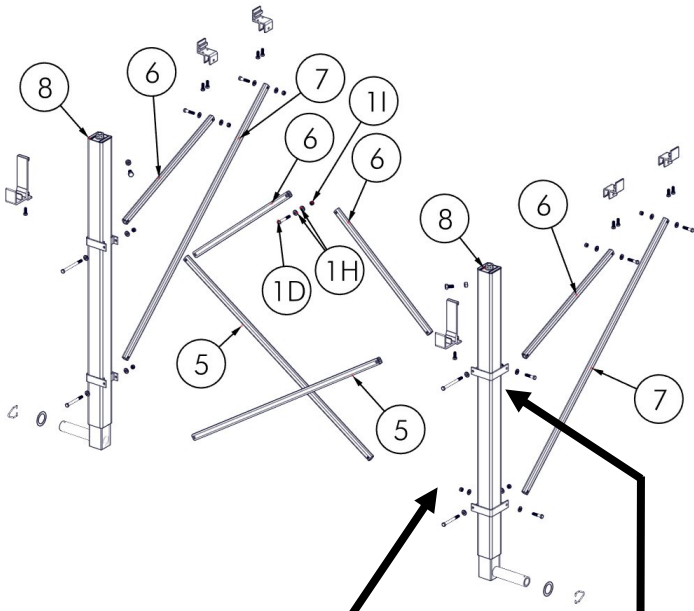

BILL OF MATERIALS

P/N 510-27510-00		WHEEL KIT, QA X-DEEP (SINGLE) BZ	
P/N 510-27610-00		WHEEL KIT, QA XX-DEEP (SINGLE) BZ	
NUMBER	PART NUMBER	QTY.	DESCRIPTION
1	001-02325-00	1	FASTENERS, QA ROLL-IN X-D/XX-D W/K SINGLE
2	002-00064-00	2	BRACKET, W/K BRACE 1.125"
3	002-00285-00	2	BRACKET, QA DOCK SIDE BRACE
4	002-00291-00	1	QUICK CONNECT, QA ROLL-IN - 2"
5	002-02087-00	1	BRACE, WHEEL KIT - 46.5"
6	002-02088-00	2	TUBE, .875" X 1.063" X 26"
7	002-02089-00	1	BRACE, WHEEL KIT 52.75"
8	110-00223-02	1	ASS'Y, LEG W/K (X-DEEP) BRONZE
	110-00226-01	1	ASS'Y, LEG W/K (XX-DEEP) BRONZE

P/N 001-02325-00		FASTENERS, QA ROLL-IN X-D/XX-D W/K SINGLE	
NUMBER	PART NUMBER	QTY.	DESCRIPTION
1A	001-26728-00	1	CLIP, STAINLESS STEEL SPINDLE
1B	001-70105-00	5	HHCS, 3/8-16 X 1" SS
1C	001-70110-00	6	HHCS, 3/8-16 X 1-3/4" 18-8 SS
1D	001-70114-00	1	HHCS, 3/8-16 X 2-3/4" 18-8 SS
1E	001-70119-00	2	HHCS, 3/8-16 X 4" 18-8 SS
1F	001-70123-00	1	HHCS, 3/8-16 X 5" 18-8 SS
1G	001-70205-00	1	HHCS, 1/2-13 X 1" SS 18-8
1H	001-71017-00	17	FLAT WASHER, 3/8" SAE SS 18-8
1I	001-76349-00	9	NUT, 3/8-16 ALUM.
1J	001-76350-00	1	NUT, 1/2-13 ALUM.
1K	010-00020-00	1	WASHER, 2.5" O.D. X 1.75" I.D.

SOLD SEPARATELY



Plastic dock wheels
 Drilled 010-06001-00
 Floating 010-06002-00

Sand pads
 P/N 510-17000-00

NOTE:
 EXTRA HARDWARE IS
 INCLUDED THAT
 MAY NOT BE USED
 IN SOME
 APPLICATIONS.

EXPLODED VIEW

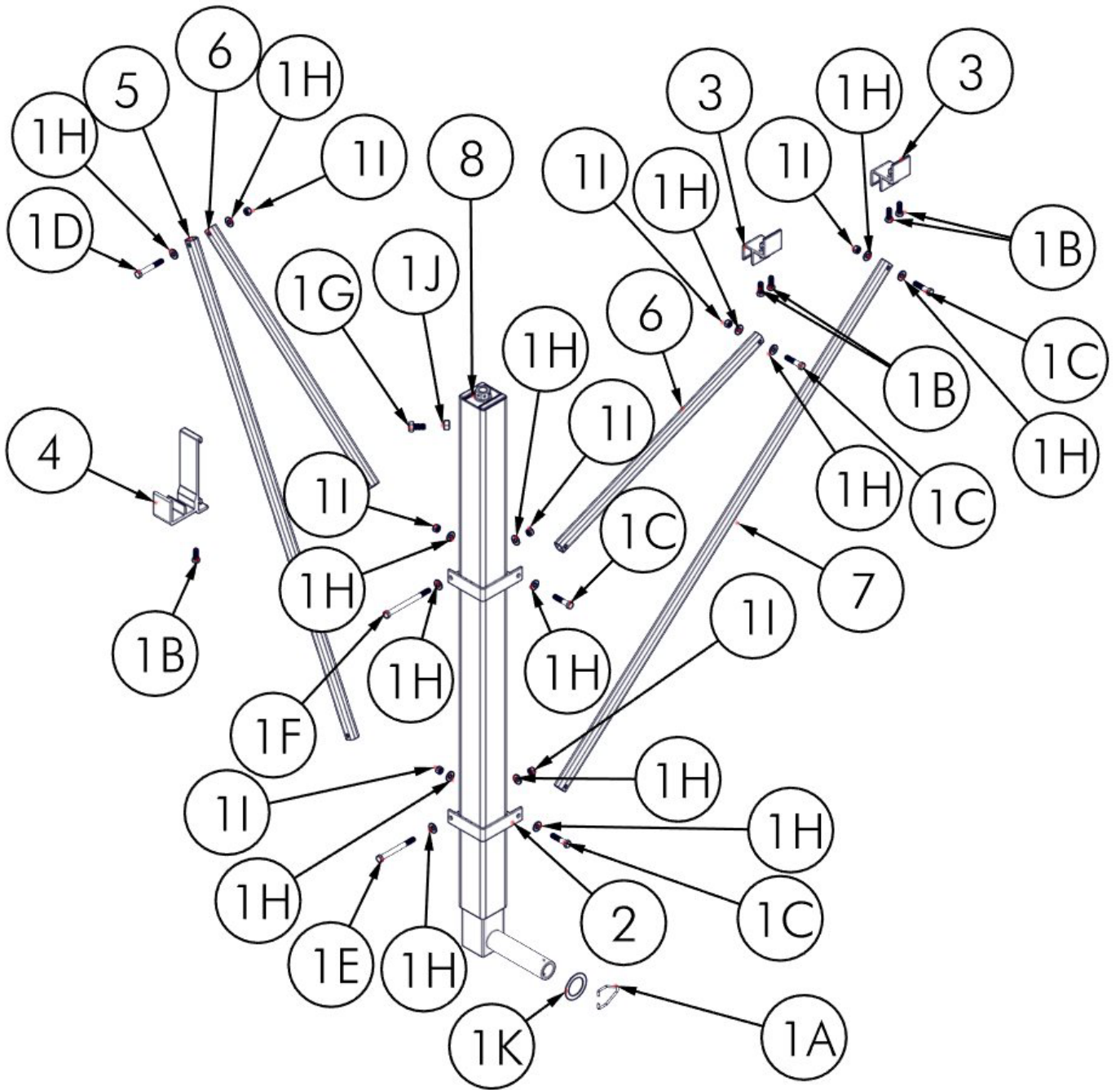

SUNDECK INSTALLATION

6' WIDE SHOWN

(NOTE: ADDITIONAL NECESSARY HARDWARE IS ATTACHED TO THE DOCK SECTION)

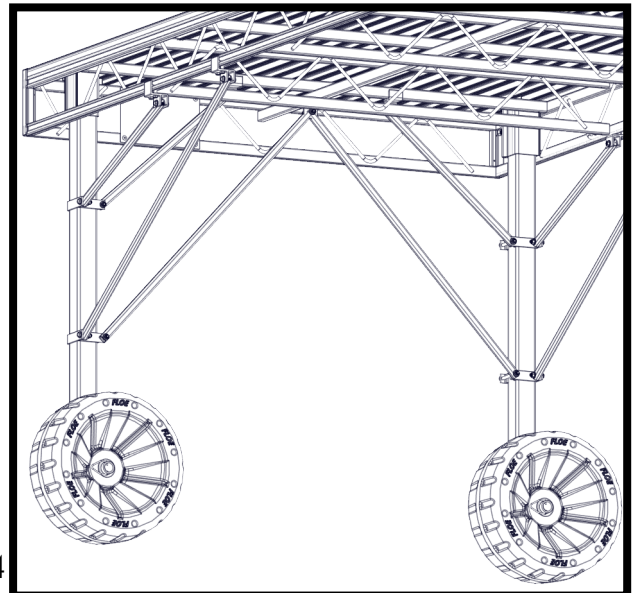
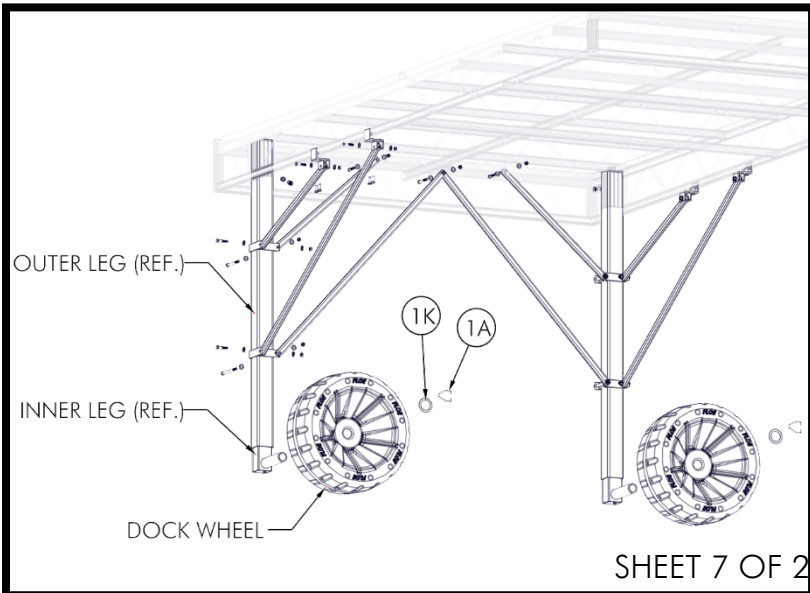
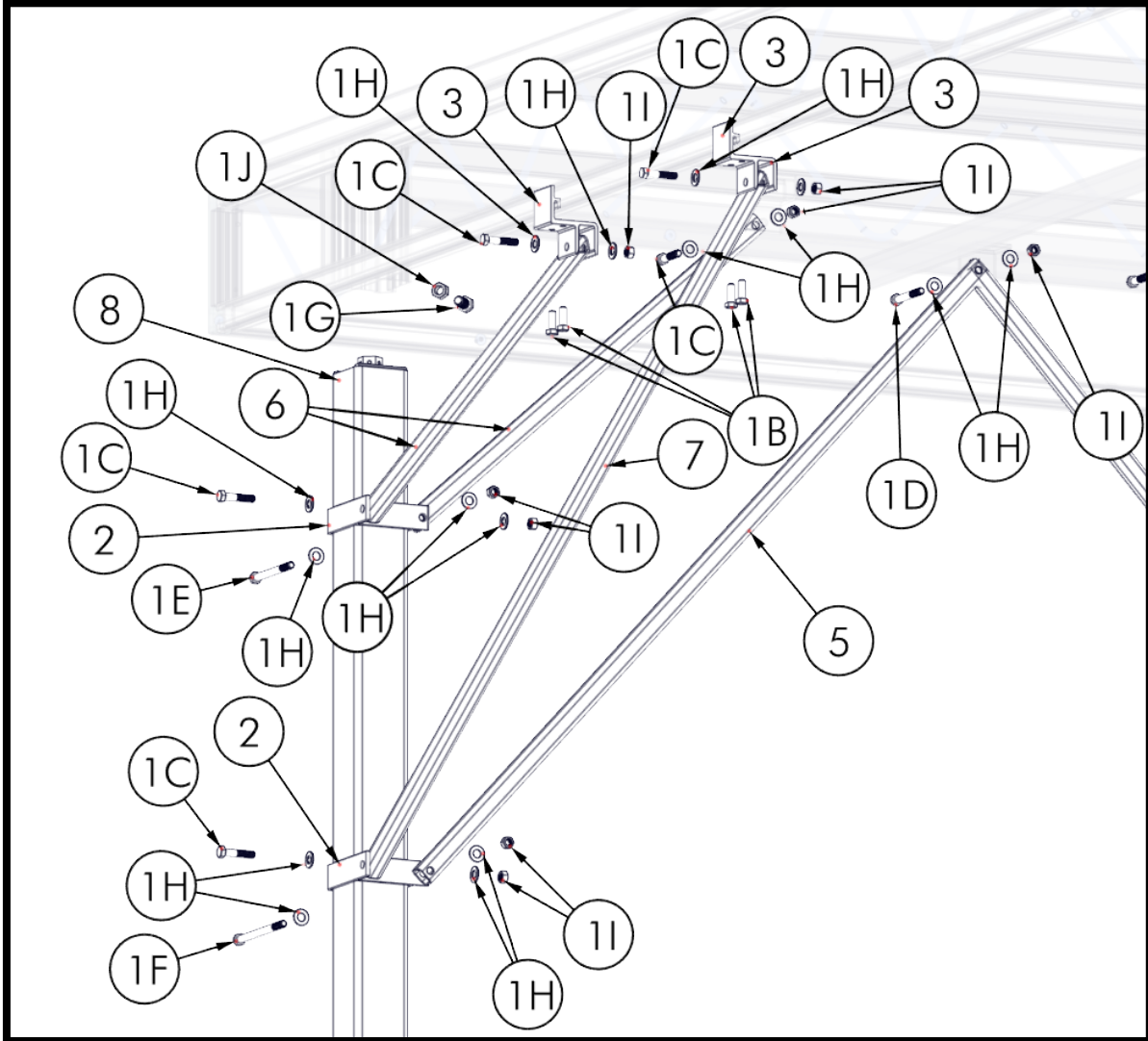

SUNDECK INSTALLATION

8' WIDE SHOWN

NOTE:

SHOWN WITH WHEELS TURNED IN. WHEN X-DEEP OR XX-DEEP WHEEL KITS ARE USED ON 8' DOCK AND SUNDECK SECTIONS, YOU WILL HAVE EXTRA PARTS (2 - 26" BRACES (002-02088-00)).

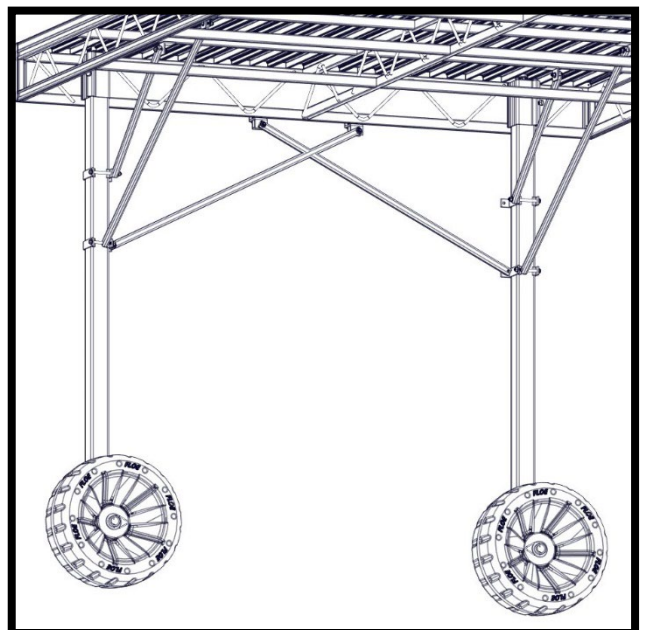
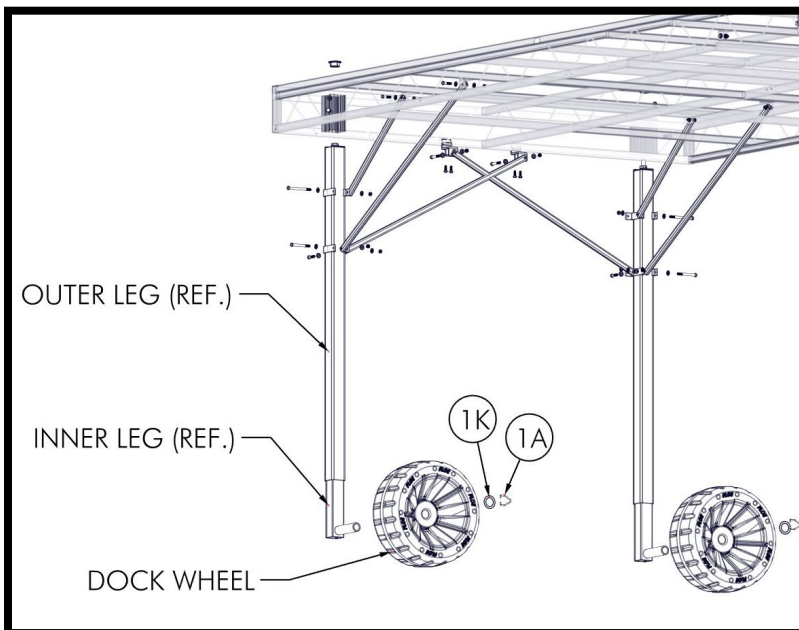
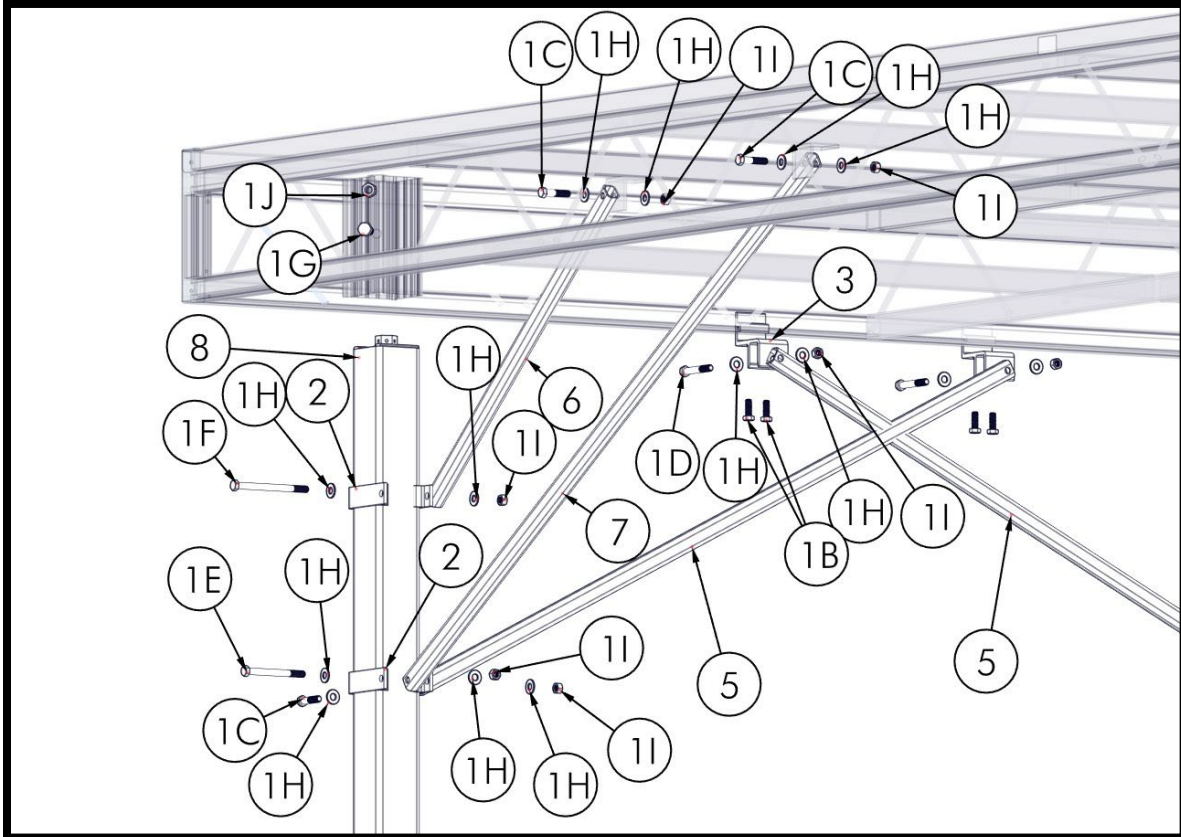

STEP 1

TURN DOCK UPSIDE DOWN AND BLOCK CORNERS (OR USE A SOFT SURFACE) TO PROTECT THE DECK SURFACE (FIGURE 1.1). INSTALL (1) 1/2" X 1" BOLT AND (1) 1/2" NUT INTO EACH POCKET WELDED ON THE DOCK (FIGURE 1.2). SLIDE THE WHEEL KIT BRACKETS ONTO THE WHEEL KIT LEGS (FIGURE 1.3).

FIGURE 1.1

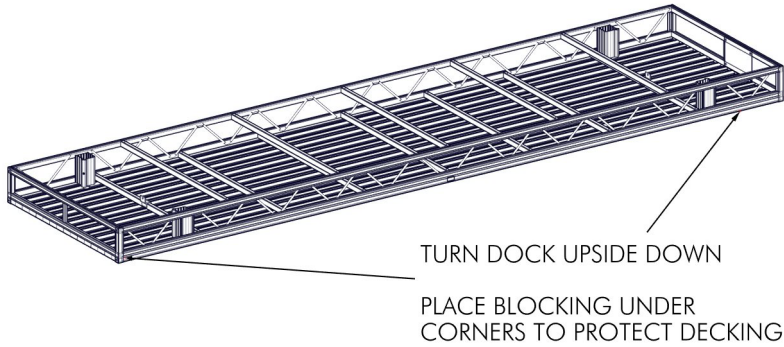

NOTE:
DIAGRAMS SHOW 4' WIDE DOCK SECTIONS. IF YOU ARE ATTACHING WHEEL KITS TO AN 8' WIDE SUNDECK, REFER TO THE EXPLODED VIEW ON SHEET 3.

FIGURE 1.2

2X

1/2" NUT

1/2" X 1" BOLT
DO NOT TIGHTEN

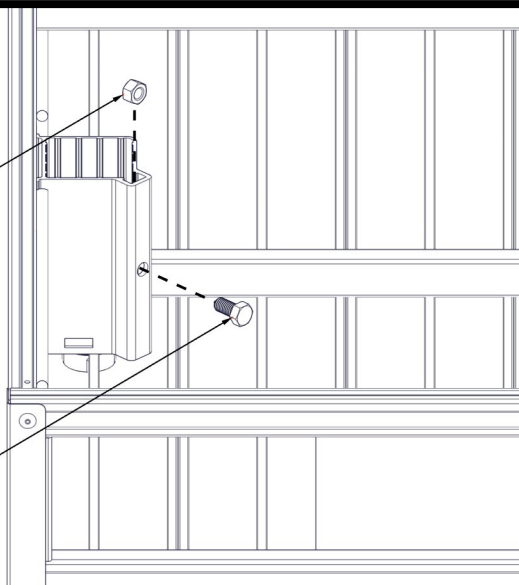

FIGURE 1.3

2X

WHEEL KIT LEG

SLIDE WHEEL KIT BRACKETS ONTO WHEEL KIT LEG

WHEEL KIT BRACES



INSERT WHEEL KIT LEGS INTO THE POCKETS THAT ARE WELDED ON THE DOCK (FIGURE 1.4). UNDER NORMAL CONDITIONS, THE WHEEL KITS ARE MOUNTED AS SHOWN IN FIGURE 1.5A. IF NECESSARY, WHEEL KITS MAY BE TURNED 180° FOR BOAT LIFT CLEARANCE. HOWEVER, SOME STABILITY MAY BE LOST (FIGURE 1.5B). REFER TO DOCK OWNER'S MANUAL FOR SPECIAL CONDITIONS ON SETTING UP YOUR DOCK. TORQUE THE 1/2" BOLT TO 20 FT-LB (FIGURE 1.6).

FIGURE 1.4

2X

SLIDE WHEEL KIT WITH BRACKETS INTO POCKET ON DOCK

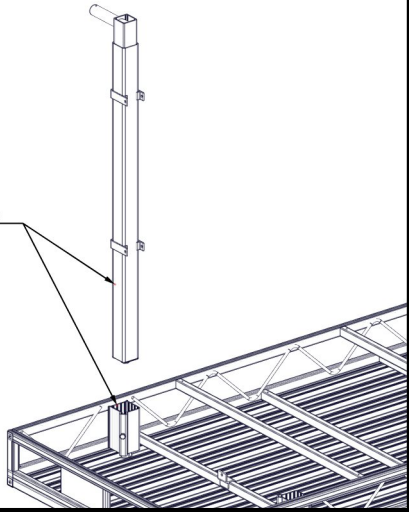
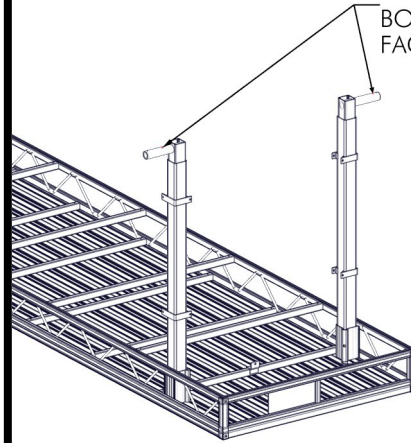

FIGURE 1.5A

STANDARD INSTALLATION

BOTH SPINDLES FACING OUTWARDS



WHEEL KIT LEG MAY BE TURNED 180° IF ROOM IS NEEDED BESIDE THE DOCK FOR A BOAT LIFT. HOWEVER, SOME STABILITY WILL BE LOST

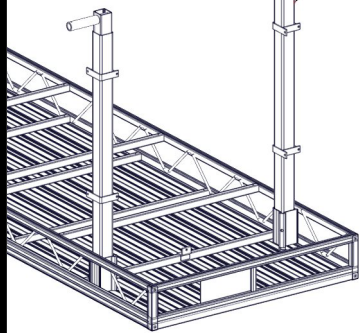
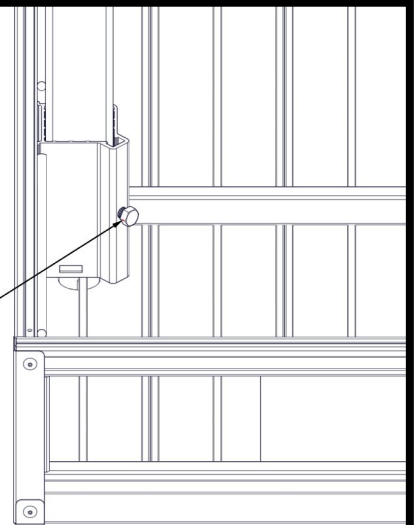

FIGURE 1.5B

TORQUE TO 20 FT-LB

2X

FIGURE 1.6



STEP 2

FOR BRACE PLACEMENT, REFER TO FIGURE 2.1. ATTACH THE 26" AND 46-1/2" CENTER BRACES TO THE WHEEL KIT BRACE BRACKET USING (1) 3/8" X 5" BOLT, (2) 3/8" WASHERS, AND (1) 3/8" NUT, PER SIDE (FIGURE 2.2).

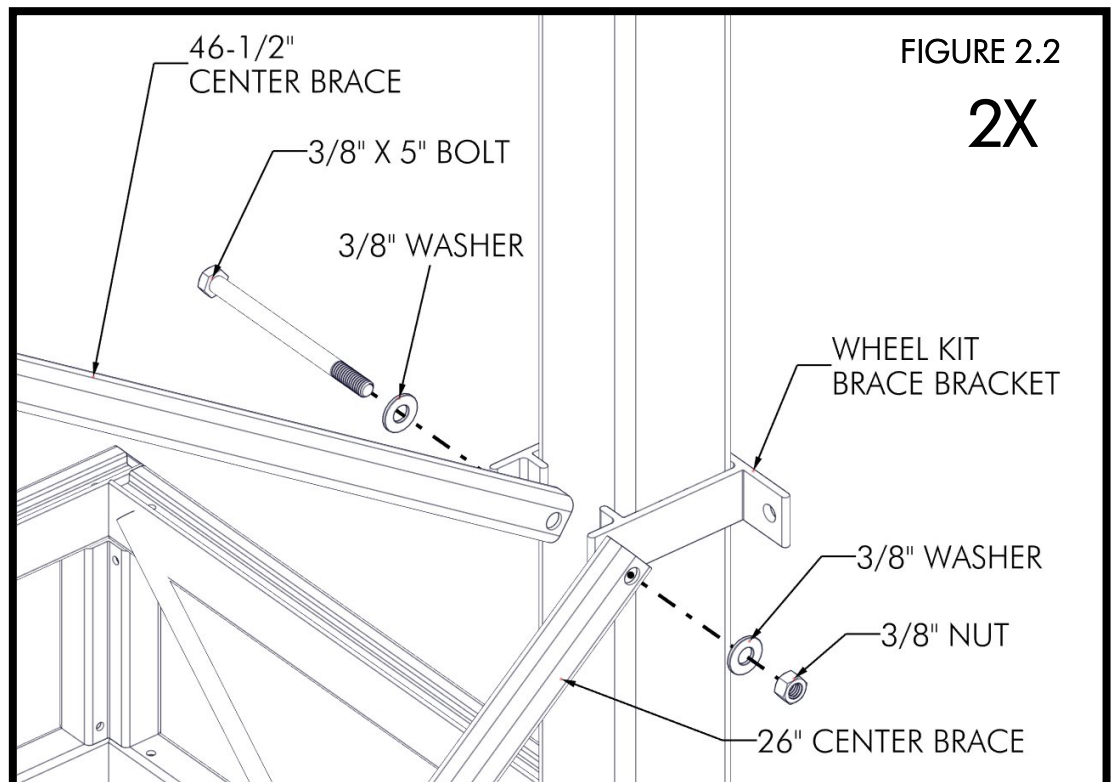
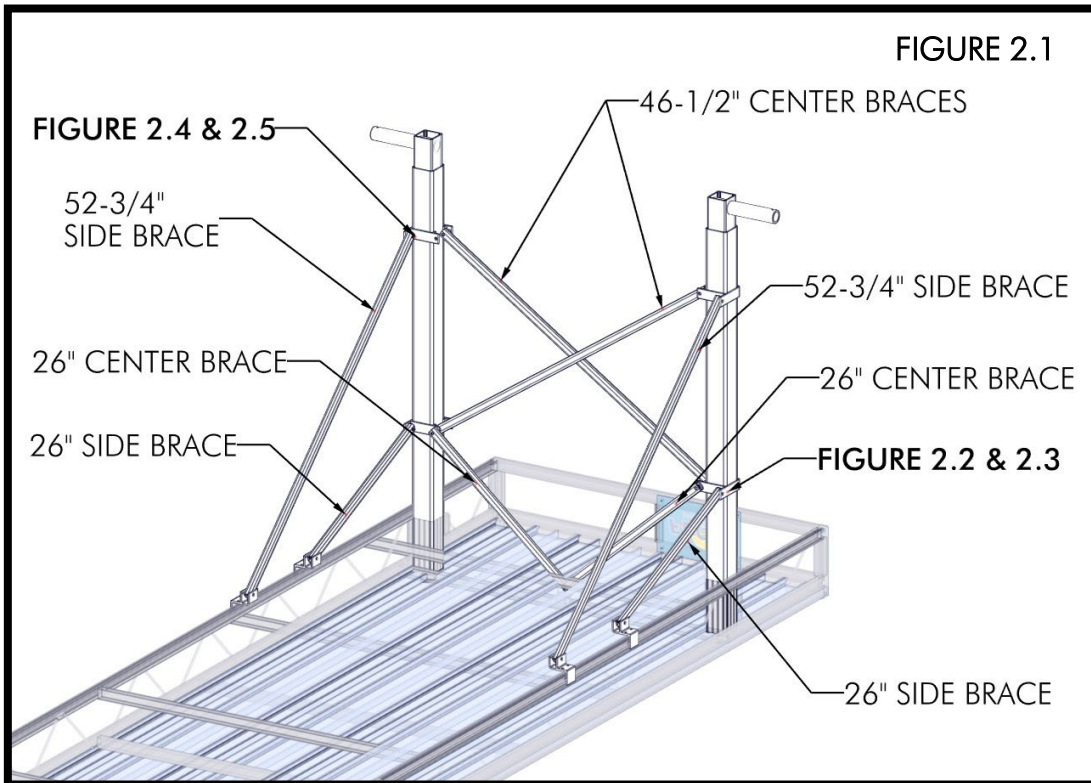

ATTACH THE 26" SIDE BRACES TO THE WHEEL KIT BRACE BRACKET USING (1) 3/8" X 1-3/4" BOLT, (2) 3/8" WASHERS, AND (1) 3/8" NUT (FIGURE 2.3). ATTACH THE OTHER END OF THE 46-1/2" TO THE WHEEL KIT BRACE BRACKET USING (1) 3/8" X 4" BOLT, (2) 3/8" WASHERS, AND (1) 3/8" NUT PER SIDE (FIGURE 2.4).

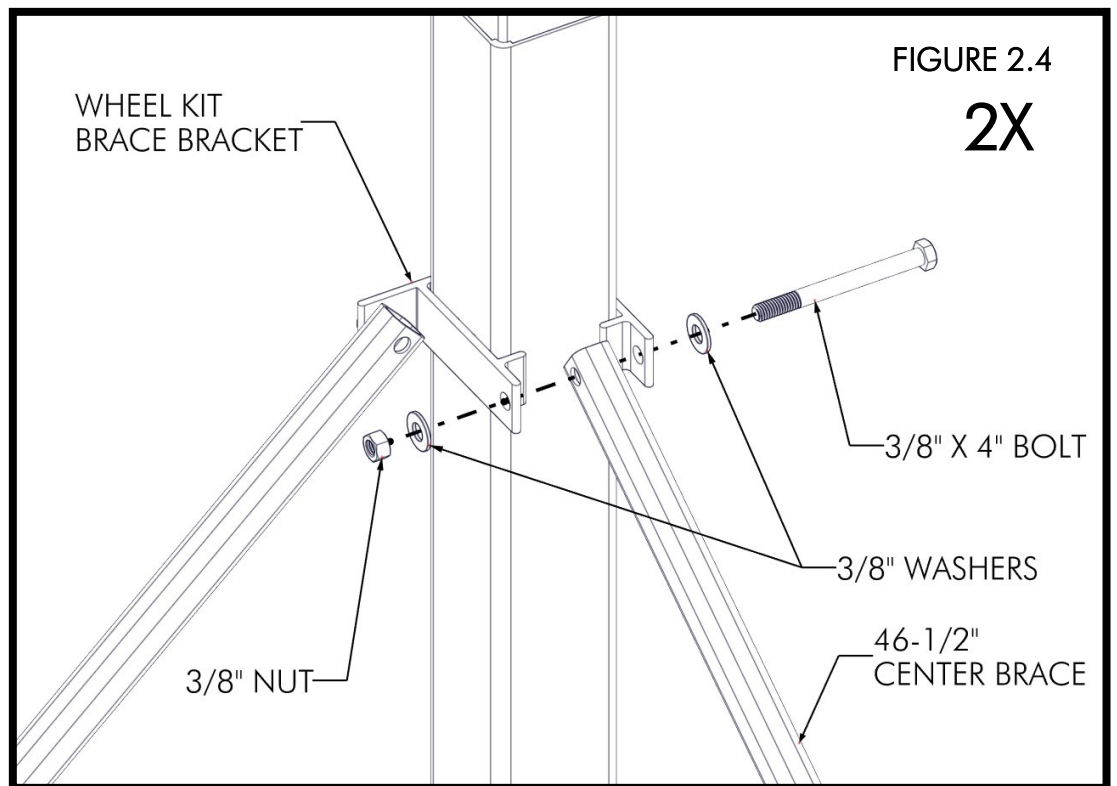
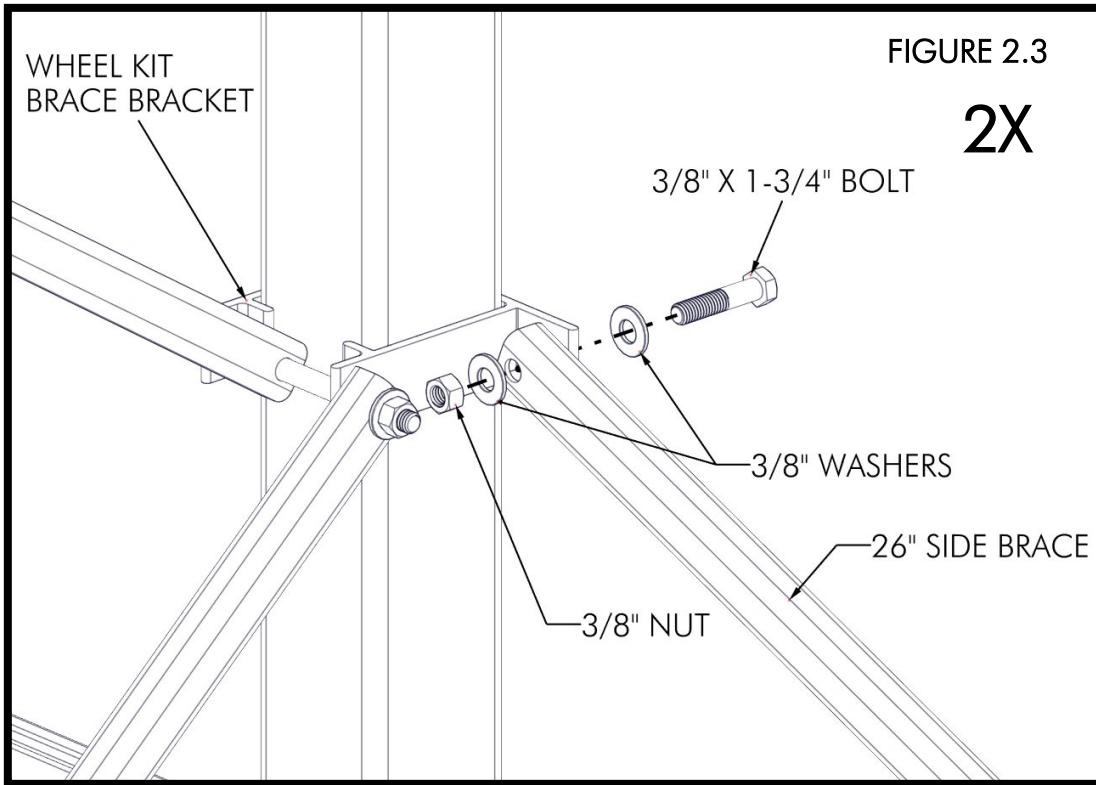

ATTACH THE 52-3/4" SIDE BRACES TO THE WHEEL KIT BRACE BRACKET USING (1) 3/8" X 1-3/4" BOLT, (2) 3/8" WASHERS, AND (1) 3/8" NUT PER SIDE (FIGURE 2.5). CONNECT THE END(S) OF THE (2) CENTER BRACE(S) TO THE BRACKET ON THE DOCK USING (1) 3/8" X 2-3/4" BOLT, (2) 3/8" WASHERS, AND (1) 3/8" NUT (FIGURE 2.6).

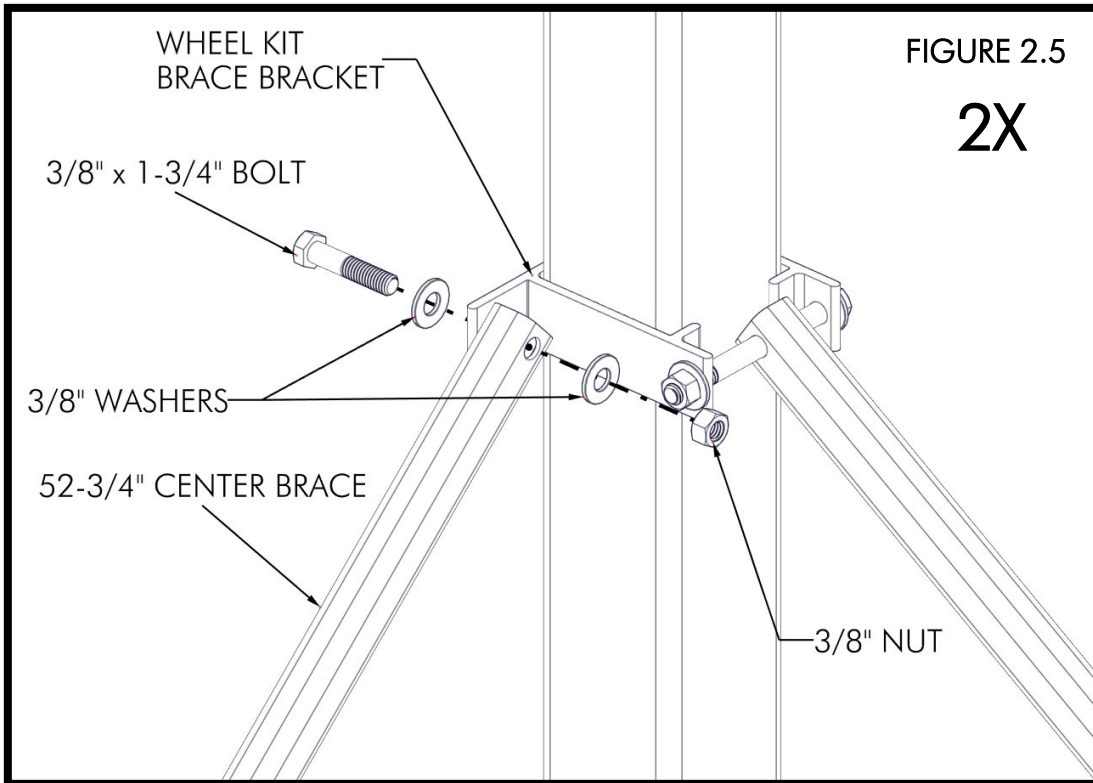

IMPORTANT:
CENTER BRACES ON 5', 6', AND 8' DOCK SECTIONS ATTACH TO INDEPENDENT BRACKETS UNLIKE 4' SECTIONS WHICH SHARE A BRACKET AS SHOWN.

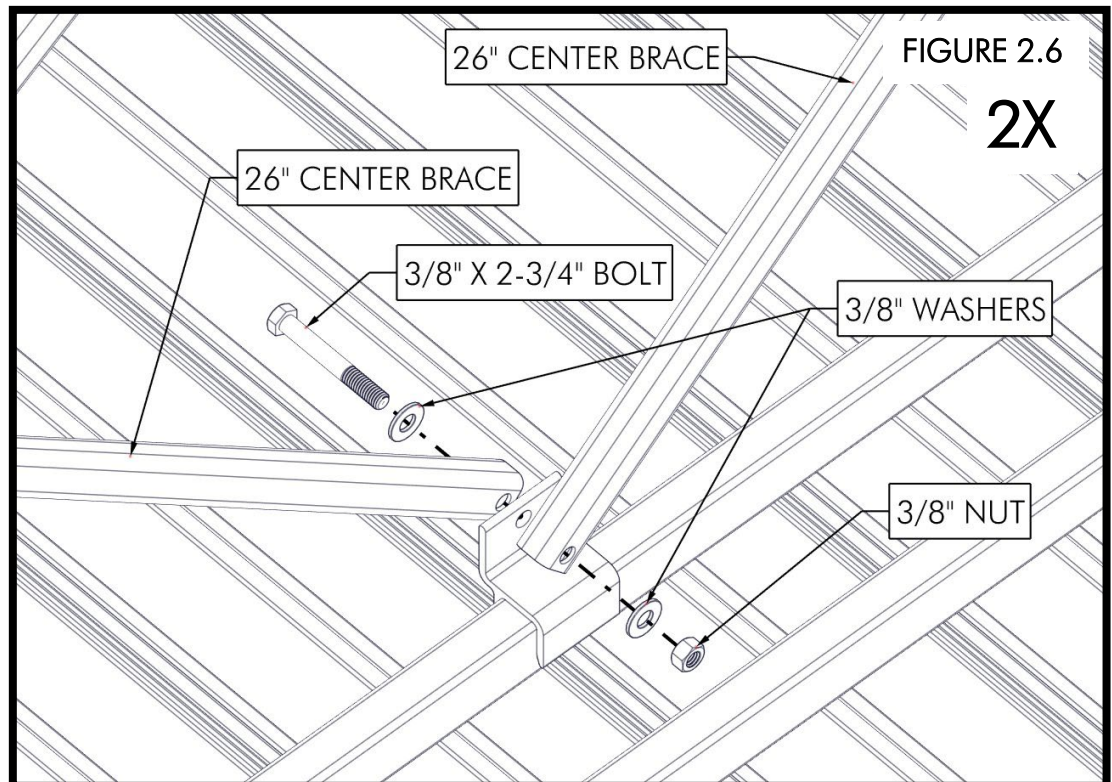

FOR SINGLE WHEEL KIT INSTALLATIONS, REFER TO FIGURE 2.7. ATTACH ONE END OF THE 26" CENTER BRACE TO THE WHEEL KIT BRACE BRACKET USING (1) 3/8" X 5" BOLT, (2) 3/8" WASHERS, AND (1) 3/8" NUT (FIGURE 2.8).

FIGURE 2.7

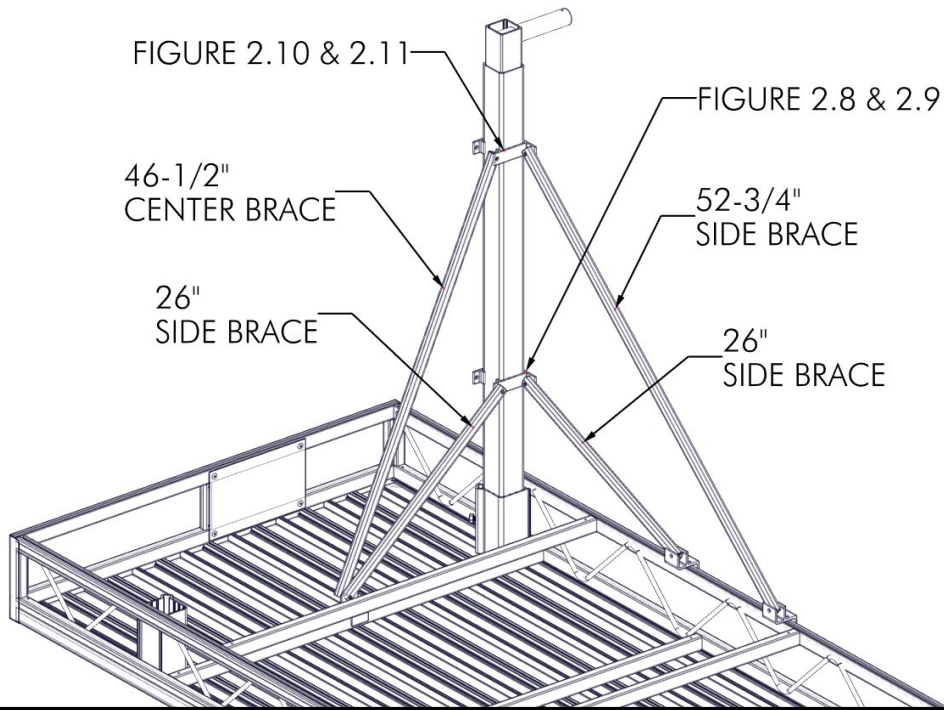
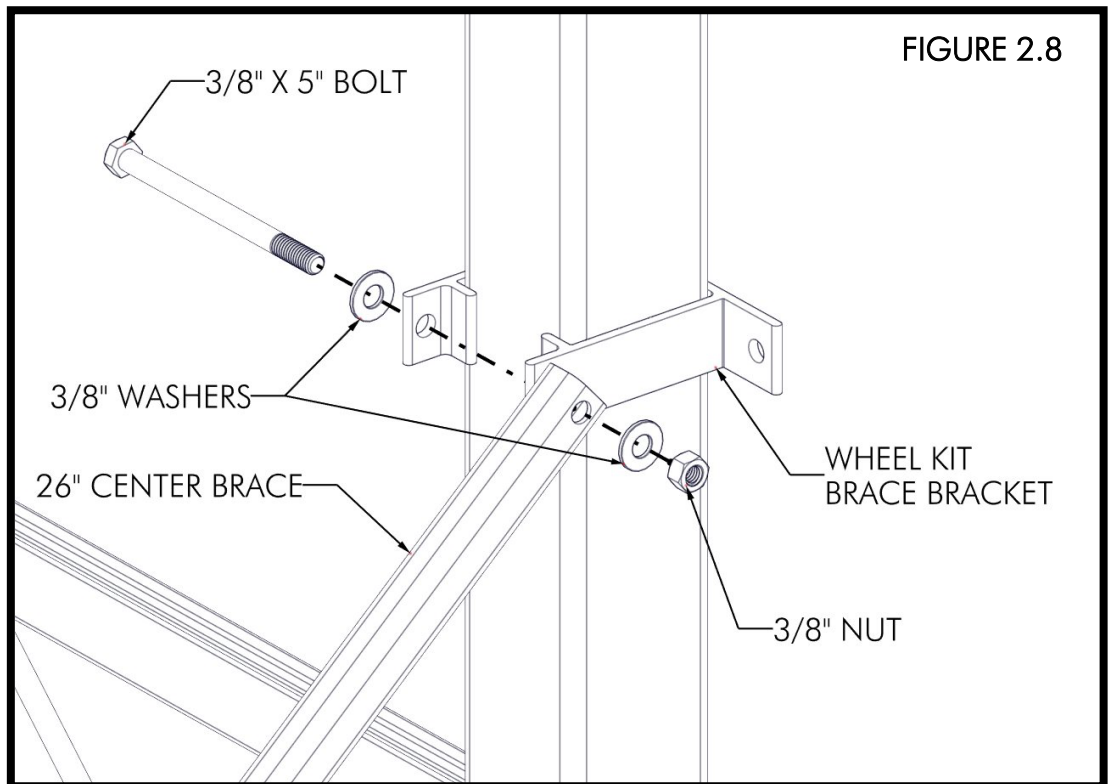
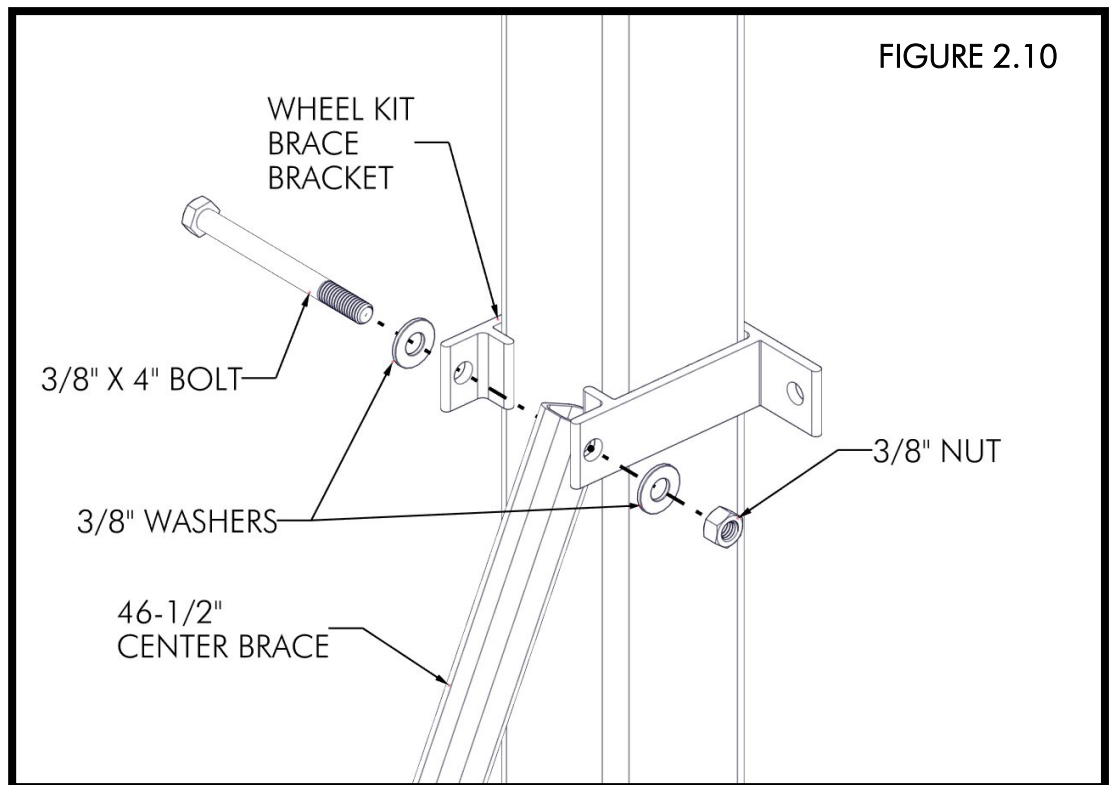
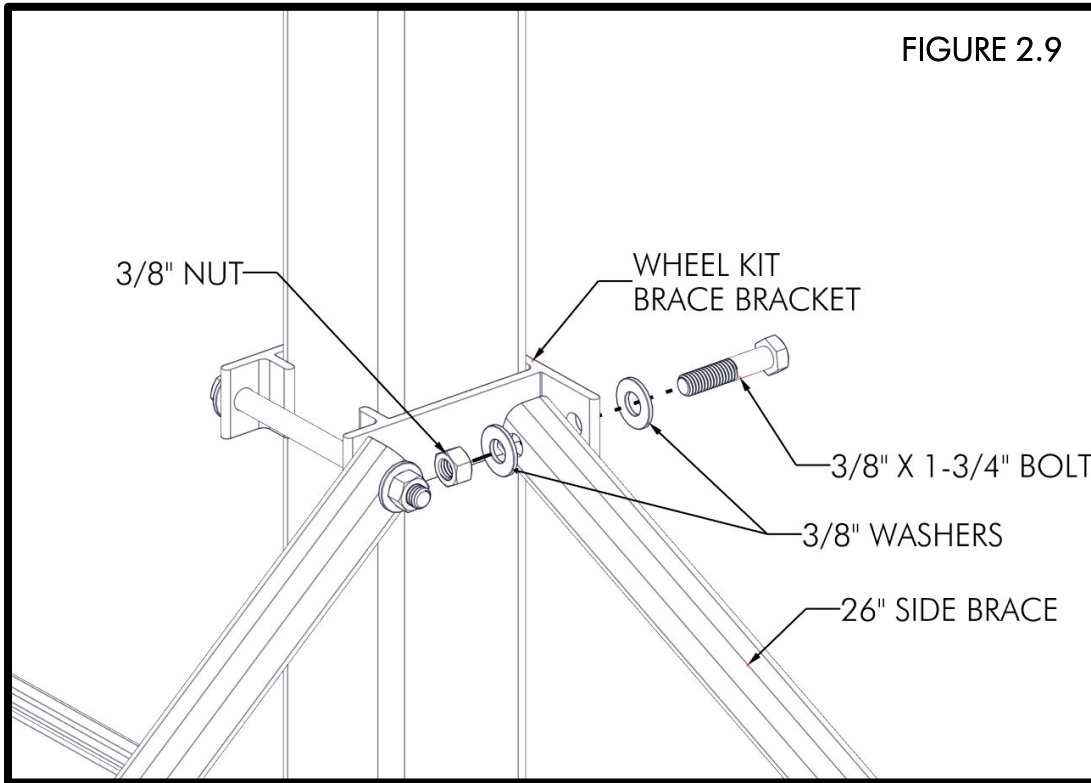

FIGURE 2.8



ATTACH ONE END OF THE 26" SIDE BRACE TO THE WHEEL KIT BRACE BRACKET USING (1) 3/8" X 1-3/4" BOLT, (2) 3/8" WASHERS, AND (1) 3/8" NUT (FIGURE 2.9). ATTACH ONE END OF THE 46-1/2" CENTER BRACE TO THE WHEEL KIT BRACE BRACKET USING (1) 3/8" X 4" BOLT, (2) 3/8" WASHERS, AND (1) 3/8" NUT (FIGURE 2.10).



ATTACH ONE END OF THE 52-3/4" SIDE BRACE TO THE WHEEL KIT BRACE BRACKET USING (1) 3/8" X 1-3/4" BOLT, (2) 3/8" WASHERS, AND (1) 3/8" NUT (FIGURE 2.11). CONNECT THE END(S) OF THE (2) CENTER BRACE(S) TO THE BRACKET ON THE DOCK USING (1) 3/8" X 2-3/4" BOLT, (2) 3/8" WASHERS, AND (1) 3/8" NUT (FIGURE 2.12).

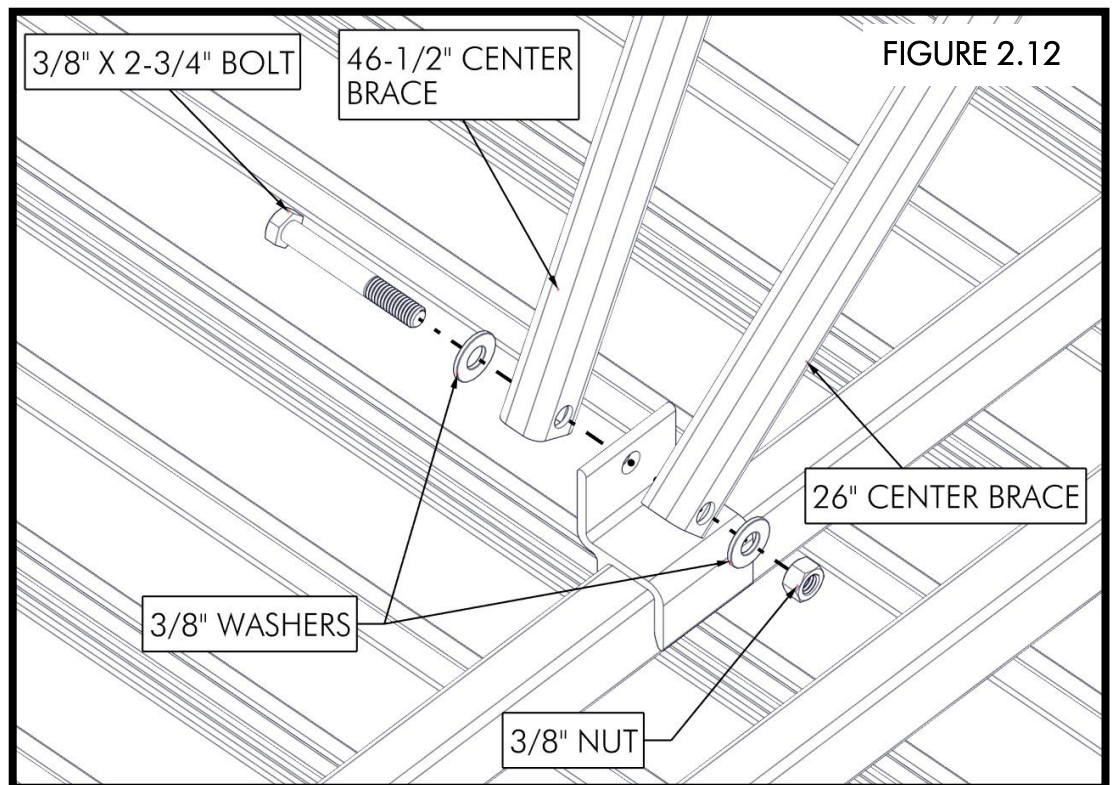
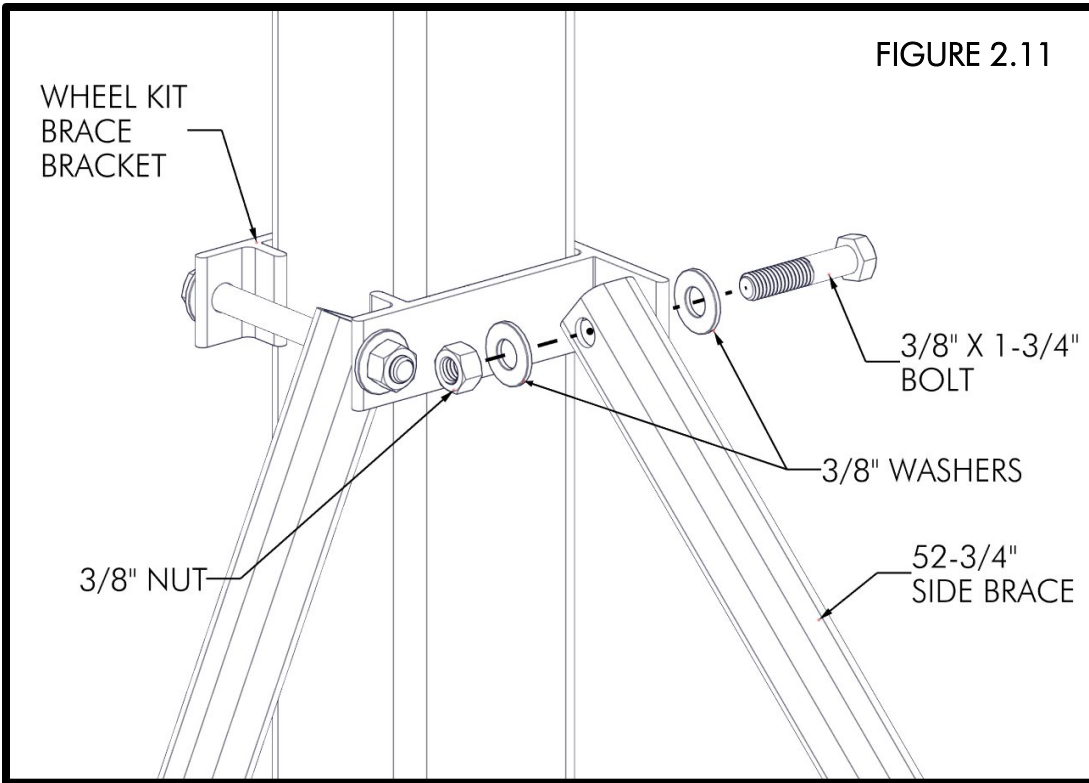

ATTACH THE ENDS OF THE 26" AND 52-3/4" SIDE BRACES TO THE DOCK SIDE BRACE BRACKET USING (1) 3/8" X 1-3/4" BOLT, (2) 3/8" WASHERS, AND (1) 3/8" NUT PER BRACKET (FIGURE 2.13). THE BRACE BRACKETS ARE ATTACHED TO THE DOCK BY PLACING THEM INTO THE DOCK SIDE (FIGURE 2.14). INSERT (2) 3/8" X 1" BOLTS INTO THE BOTTOM OF THE BRACKET (FIGURE 2.15).

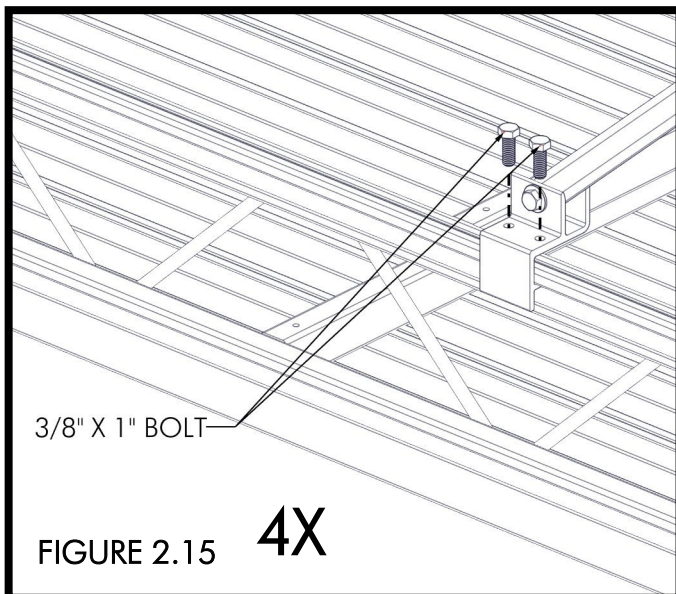
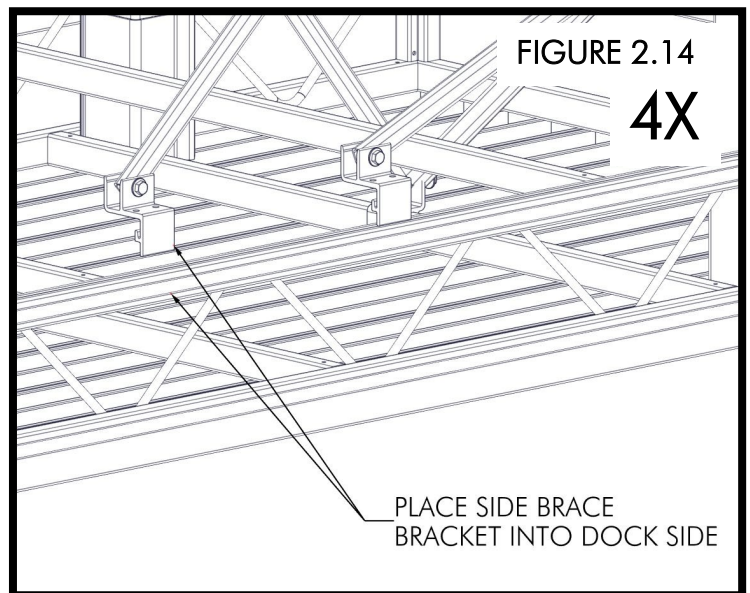
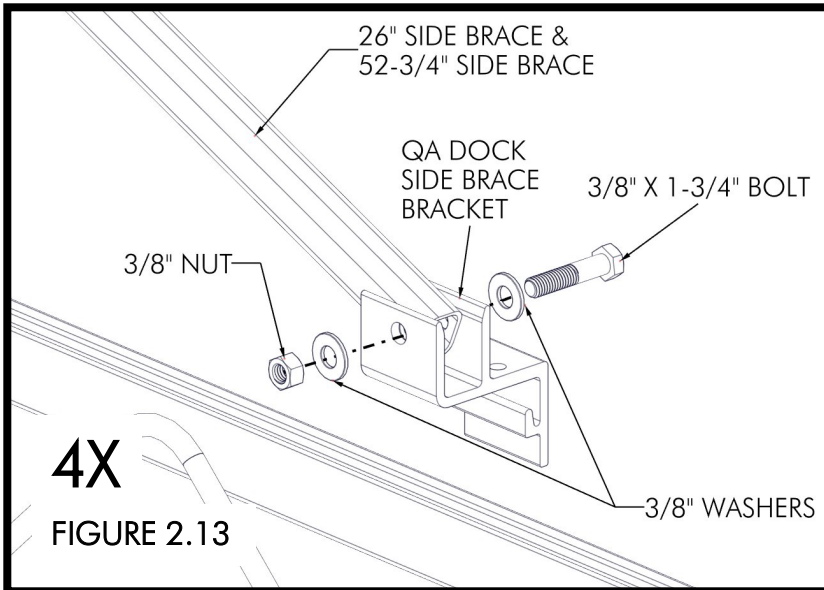

TORQUE TO 6 FT-LBS MAXIMUM (FIGURE 2.16). TORQUE ALL 3/8" NUTS INSTALLED IN THIS STEP TO THE SPECIFICATIONS SHOWN. OVERTIGHTENING THE FASTENERS WILL CRUSH THE BRACES (FIGURE 2.17).

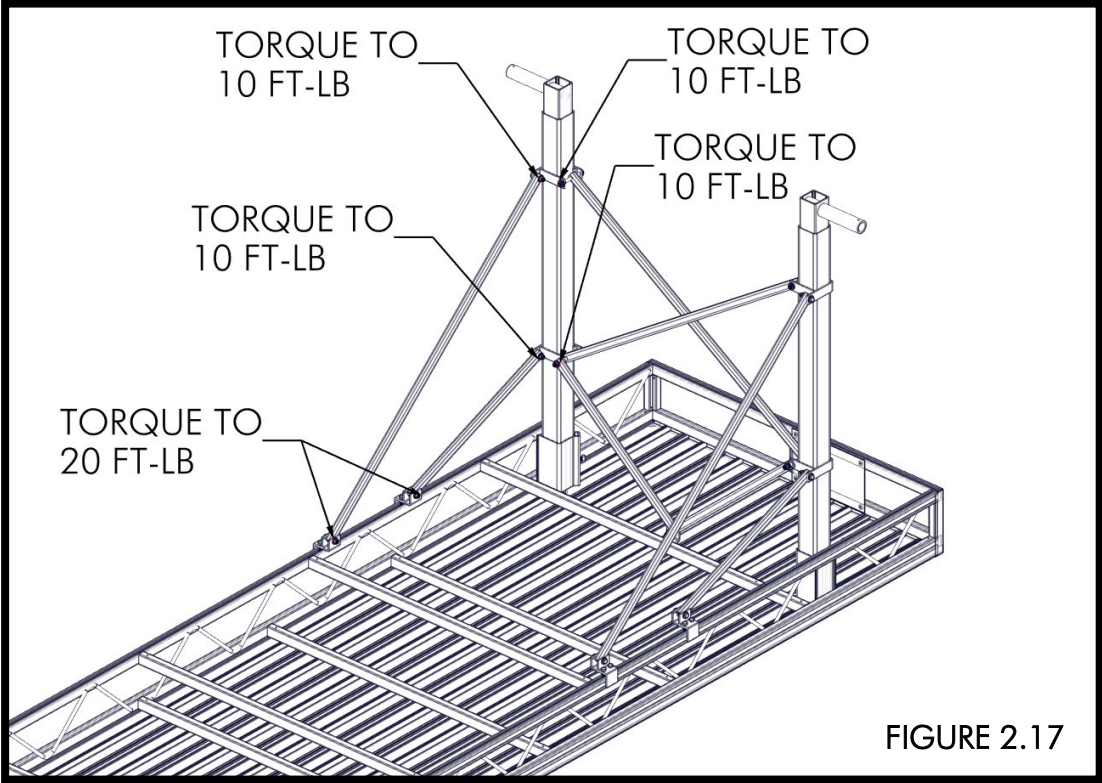
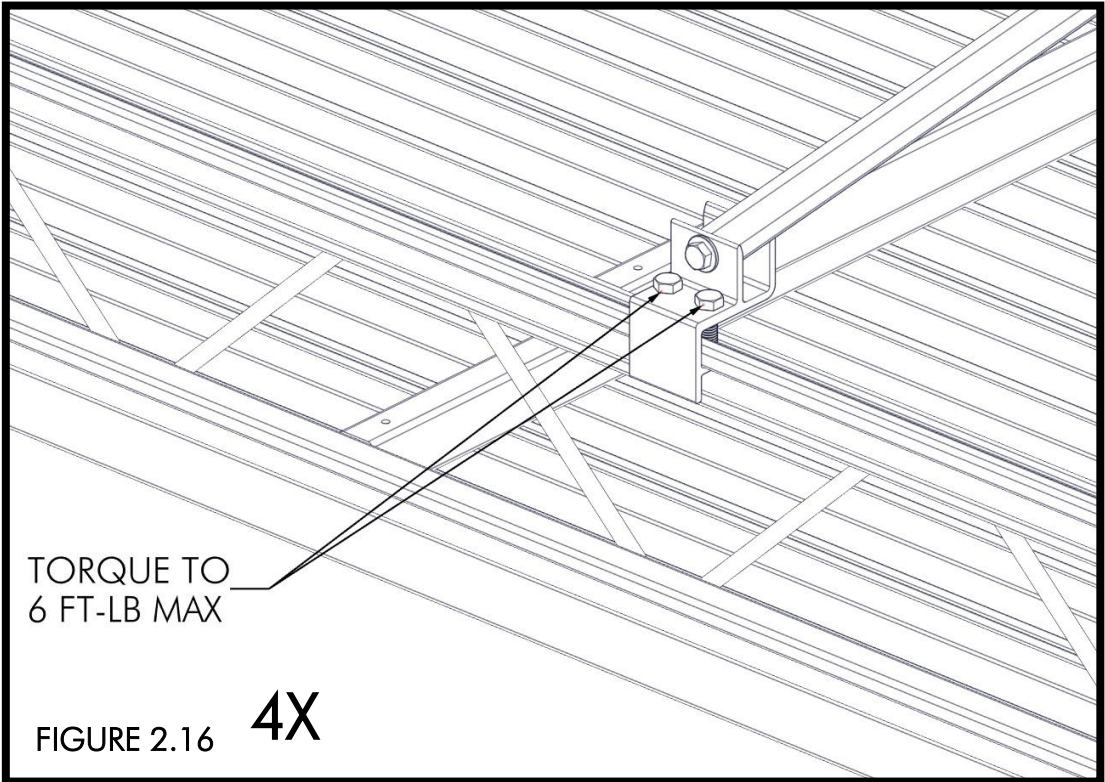

STEP 3

SLIDE WHEEL(S) (SOLD SEPARATELY) ONTO THE SPINDLE ON THE WHEEL KIT AND PLACE A 2-1/2" WASHER ONTO THE SPINDLE (FIGURE 3.1). INSERT SPINDLE CLIP LEG INTO ONE OF THE HOLES IN THE SPINDLE, THEN PULL CLIP DOWN TO SNAP OTHER CLIP LEG INTO THE SECOND HOLE (FIGURE 3.2).

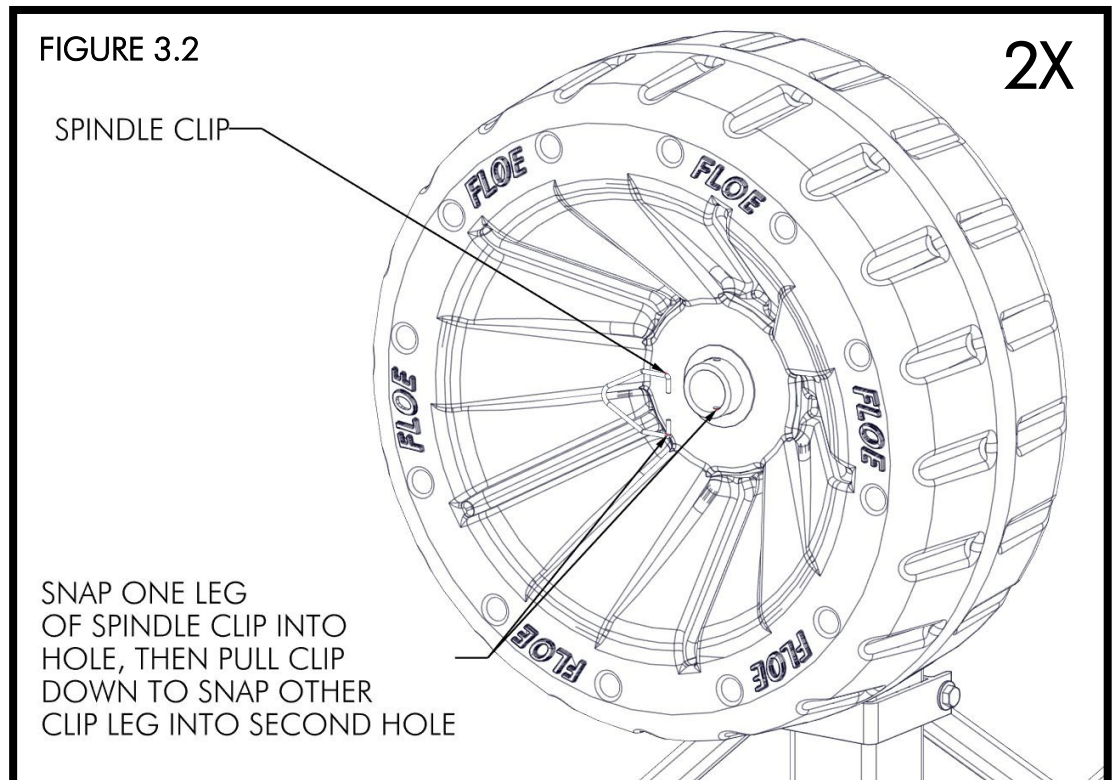
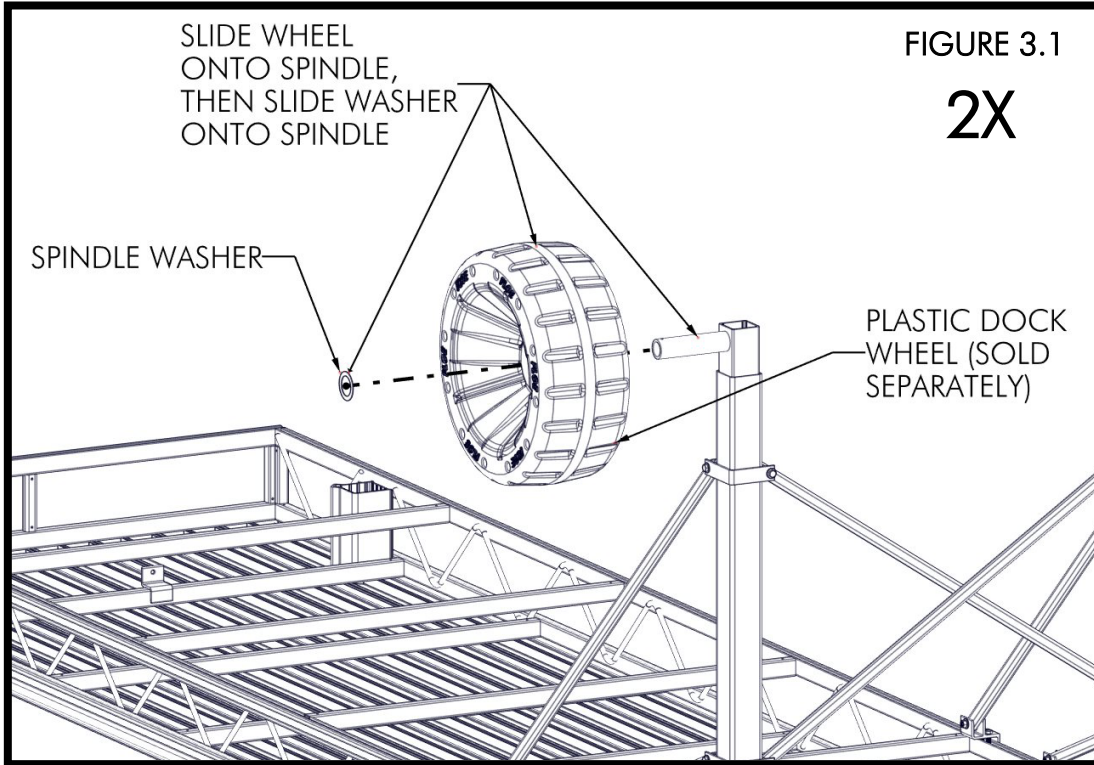

STEP 4

TURN DOCK RIGHT SIDE UP (FIGURE 4.1). ATTACH QUICK CONNECTS TO THE WHEEL KIT END OF THE DOCK SECTION IF ANOTHER SECTION IS TO BE CONNECT TO IT. TO ATTACH DOCK SECTIONS IN A STRAIGHT LINE, QUICK CONNECTS SHOULD BE ASSEMBLED AS SHOWN. SPACE THE QUICK CONNECTS AS FAR OUT AS POSSIBLE BY POSITIONING THE BRACKETS 1-5/8" FROM THE OUTSIDE OF THE DOCK TO THE OUTSIDE OF THE BRACKET (THERE WILL BE APPROXIMATELY A 1/4" GAP BETWEEN THE BRACKET AND THE INSIDE OF THE COVER) (FIGURE 4.2 & 4.4).

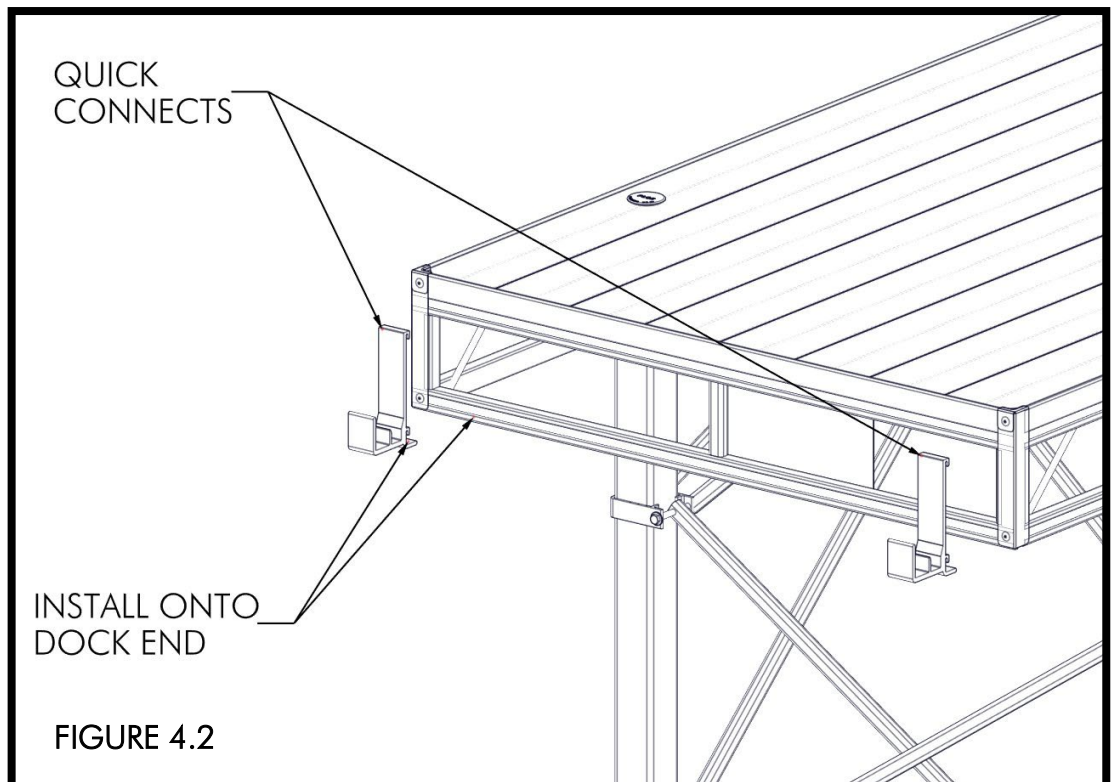
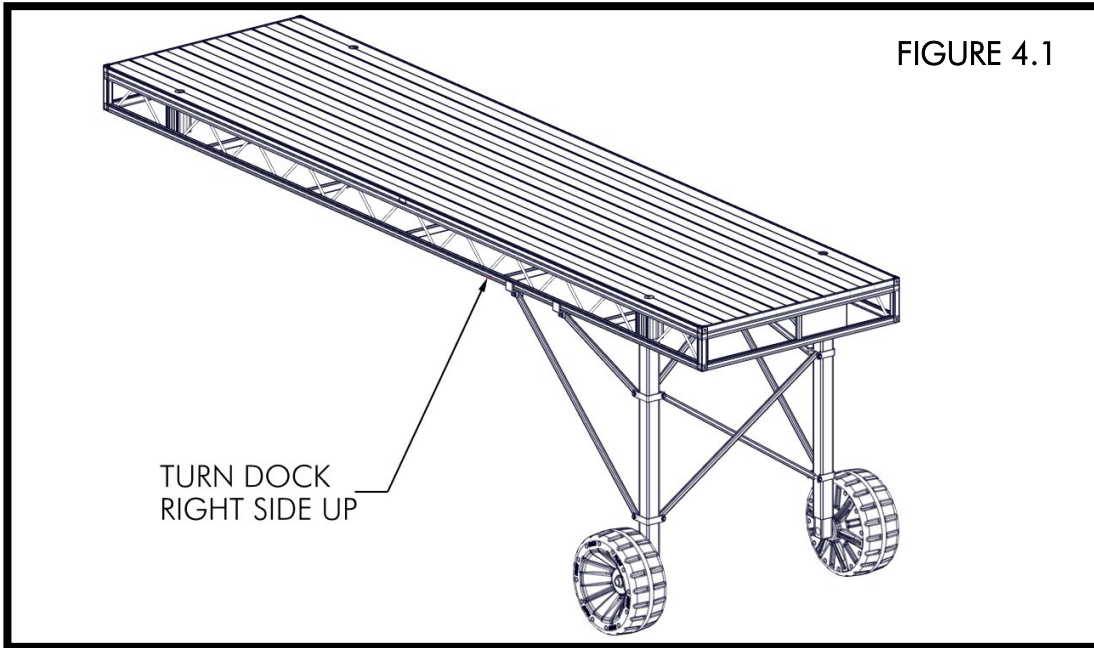

WHEN ANOTHER DOCK SECTION CONNECTS TO A SIDE OF THE DOCK, QUICK CONNECTS SHOULD BE PLACED AS SHOWN (FIGURE 4.3). ATTACH USING A 3/8" X 1" BOLT PER CONNECT. POSITION THE BRACKETS 1-5/8" FROM THE OUTSIDE OF THE DOCK TO THE OUTSIDE OF THE BRACKET (THERE WILL BE APPROXIMATELY A 1/4" GAP BETWEEN THE BRACKET AND THE INSIDE OF THE COVER) (FIGURE 4.4).

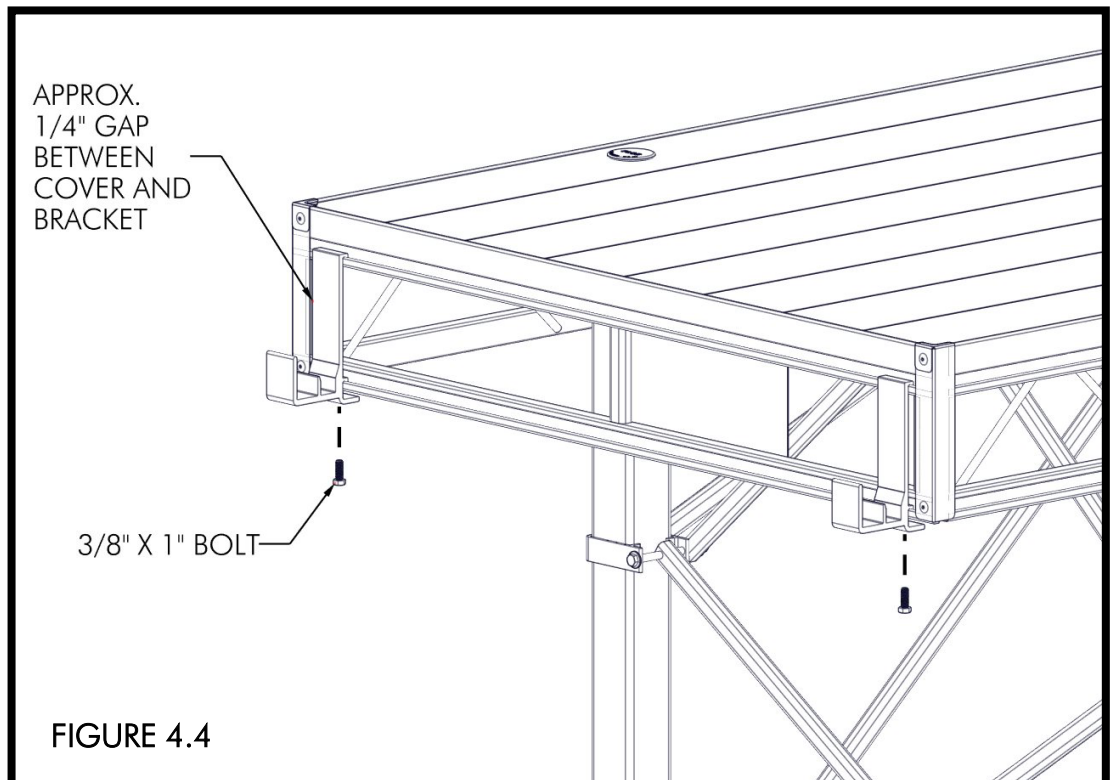
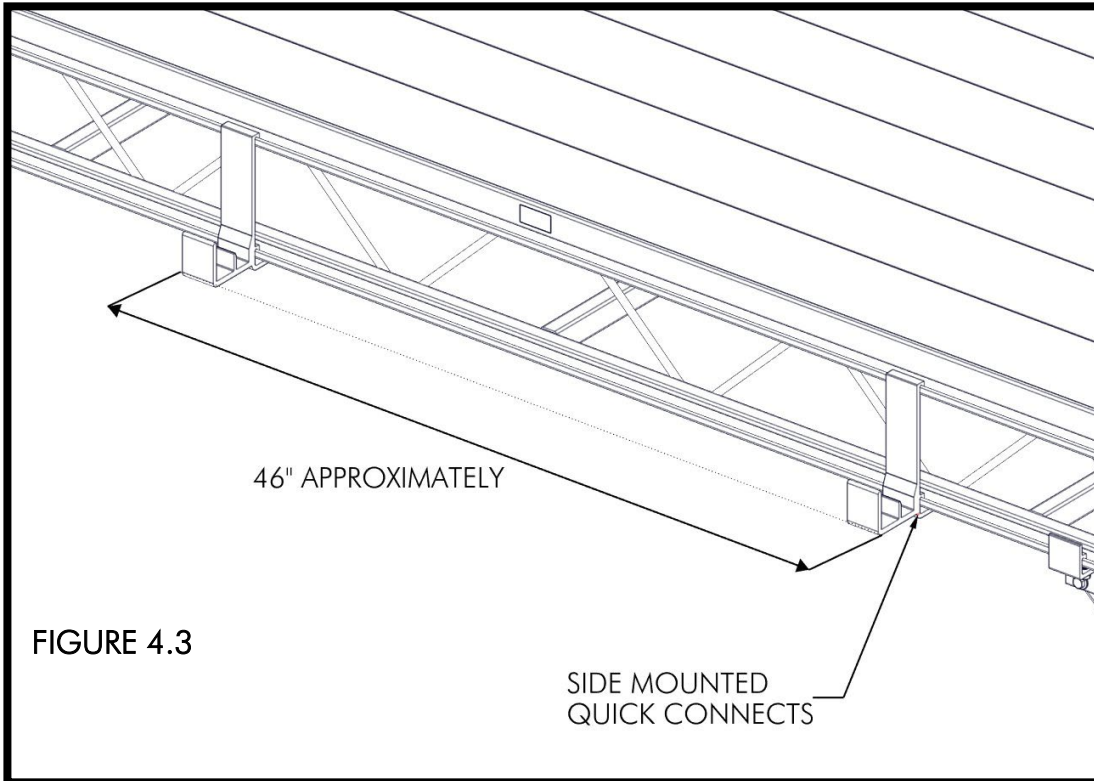

TORQUE BOLTS TO 6 FT-LBS (FIGURE 4.5). **QUICK CONNECTS SHOULD BE SPREAD APART AS FAR AS POSSIBLE TO KEEP THE JOINING SECTION FROM SHIFTING SIDWAYS.** PLACE CONNECTING DOCK SECTIONS IN THE QUICK CONNECT INSTALLATION/REMOVAL POSITION WHEN INSTALLING OR REMOVING MULTIPLE SECTIONS. PUSH THE DOCKS INTO POSITION IN THE WATER. ONCE THE DOCKS ARE IN POSITION, PUT THEM IN THE QUICK CONNECTS SET POSITION (FIGURE 4.6).

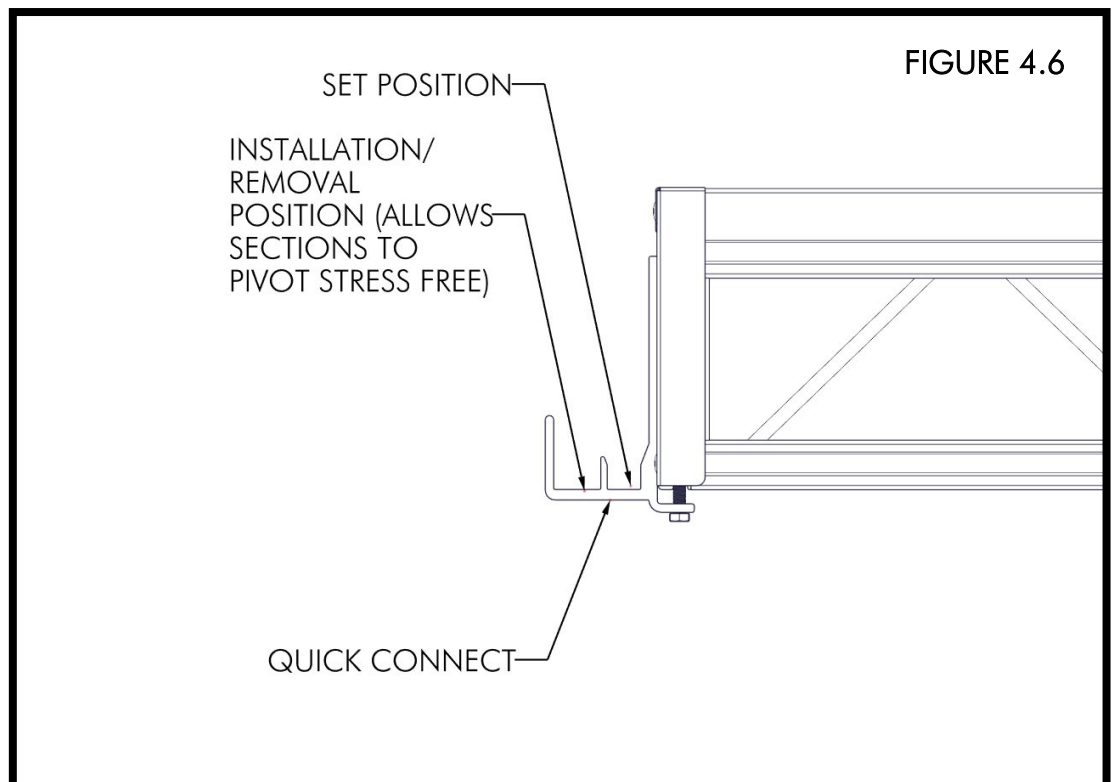
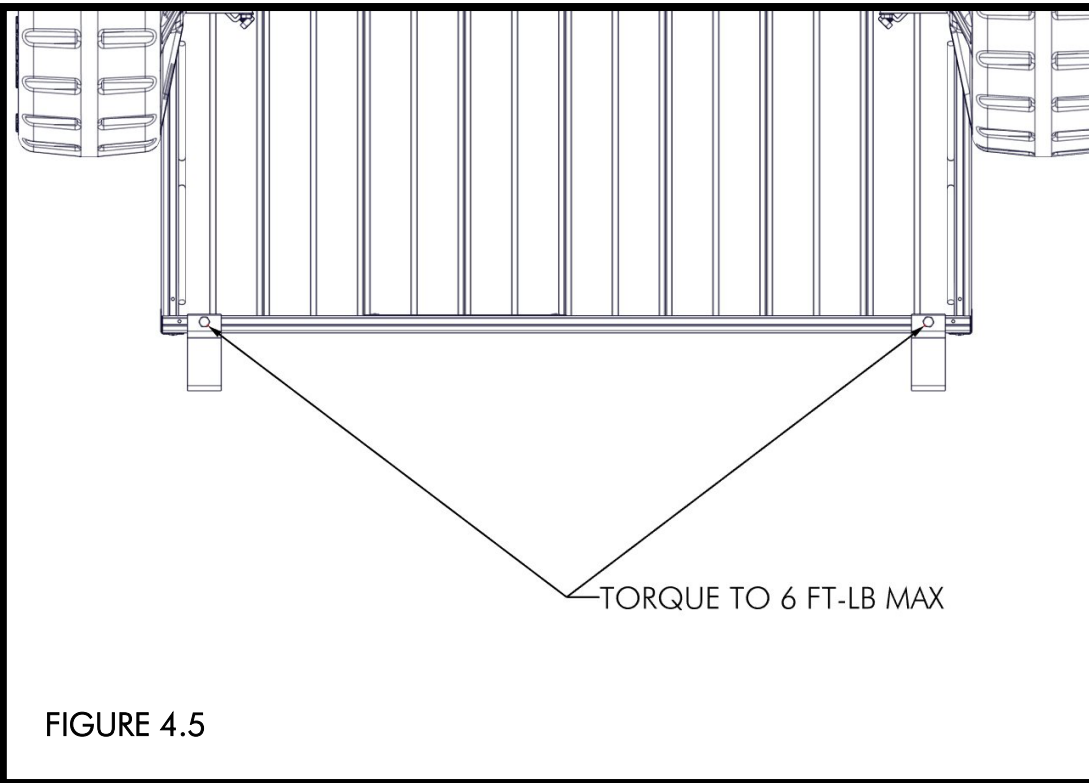

WITH THE CAPS REMOVED FROM THE DOCK, USE A FLOE SPEED WRENCH OR 1-1/8" SOCKET AND DRILL TO ADJUST THE HEIGHT OF THE DOCK SO THE BOTTOM FRAME OF THE DOCK IS APPROXIMATELY 8" ABOVE THE WATER. *SEE NOTE ON SHEET 1. TURN THE DOCK ADJUSTING NUT ON THE TOP OF THE DOCK CLOCKWISE TO LOWER THE DOCK AND COUNTERCLOCKWISE TO RAISE THE DOCK. USE A LEVEL TO MAKE SURE ALL DOCK SURFACES ARE LEVEL (FIGURE 4.7). ONCE THE DOCK IS SET IN PLACE AND LEVELED, RE-INSERT THE PLASTIC CAPS IN THE ADJUSTMENT NUT HOLE (FIGURE 4.8).

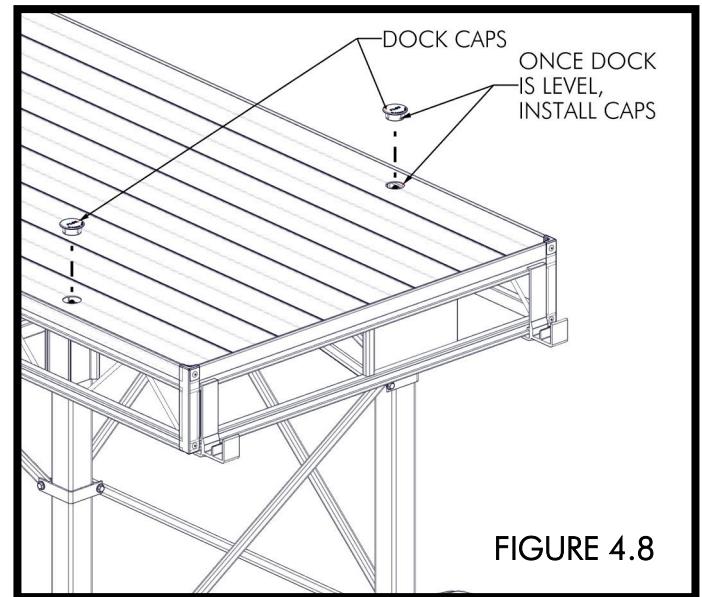
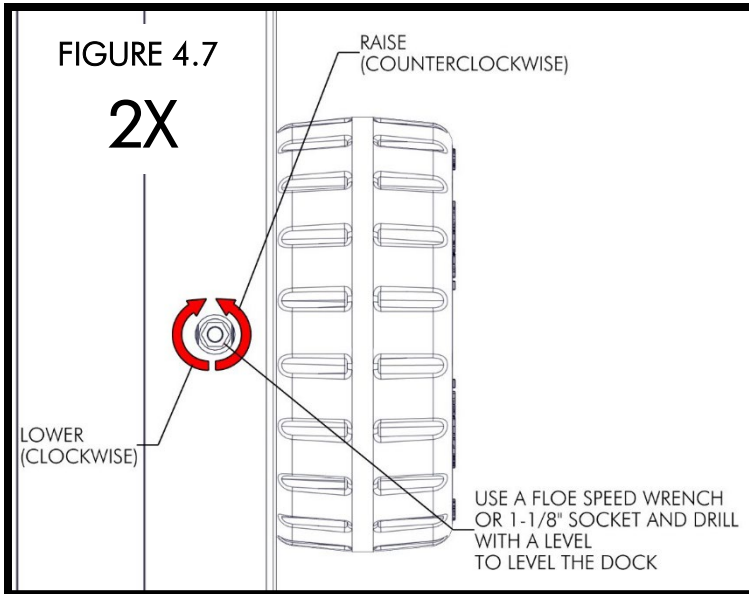

! WARNING !

CORDLESS DRILL MAY COME TO A SUDDEN STOP WHEN THE LEG IS FULLY EXTENDED OR RETRACTED.

BE SURE TO HAVE YOUR CORDLESS DRILL IN CLUTCH MODE WHEN ADJUSTING THE LEGS. USE OF A CORDED DRILL MAY CAUSE ELECTROCUTION. FAILURE TO USE DRILL IN CLUTCH MODE MAY CAUSE INJURY TO YOUR HAND OR ARM.

! WARNING !

NEVER ADJUST YOUR DOCK LEGS WITH AN IMPACT WRENCH. IF YOU CAN NOT TURN THE ADJUSTING NUT, DO NOT FORCE IT – YOU HAVE REACHED THE END OF THE ADJUSTMENT RANGE. DO NOT EXCEED 15 FT-LBS. APPLYING TOO MUCH FORCE TO YOUR DOCK LEGS WILL DAMAGE THE MECHANISM.

