

# FLOE QUICK ATTACH & STANDARD SECTIONAL DOCK AND LEG KITS

## ASSEMBLY INSTRUCTIONS

KIT P/N 510-02520-01 XX-SHALLOW (WATER DEPTHS 0"-8")

KIT P/N 510-02521-01 X-SHALLOW (WATER DEPTHS 8"-22")

KIT P/N 510-02522-01 SHALLOW (WATER DEPTHS 18"-38")

KIT P/N 510-02523-01 MEDIUM (WATER DEPTHS 28"-54")

KIT P/N 510-02524-01 DEEP (WATER DEPTHS 42"-82")



**SECTIONAL DOCK OWNERS MANUAL IS LOCATED ONLINE AT  
FLOEINTL.COM/MANUALS-AND-INFORMATION**



## WARNING

NEVER ADJUST YOUR DOCK LEGS WITH AN IMPACT WRENCH. NEVER ADJUST YOUR DOCK LEGS WITH MORE THAN 15 FT-LBS OF FORCE. APPLYING TOO MUCH FORCE TO YOUR DOCK LEGS WILL DAMAGE THE MECHANISM.

### TOOLS REQUIRED

- 7/32" ALLEN HEAD SOCKET (STD. SECTIONAL)
- (2) 9/16" SOCKETS/WRENCHES
- CORDLESS DRILL WITH SOCKET ADAPTER & 1-1/8" SOCKET OR FLOE SPEED WRENCH
- 13/32" DRILL BIT
- TORQUE WRENCH
- TAPE MEASURE
- LEVEL
- BLOCKING MATERIAL

### NOTE:

FOR INSTALLS USING LARGE WELDED SAND PAD KITS, REFER TO THESE INSTRUCTIONS IN CONJUNCTION WITH THE INCLUDED INSTRUCTIONS WITH THE SAND PAD KIT

## BILL OF MATERIALS/EXPLODED VIEW

KIT P/N 510-02520-01 XX-SHALLOW (WATER DEPTHS 0"-8")

KIT P/N 510-02521-01 X-SHALLOW (WATER DEPTHS 8"-22")

KIT P/N 510-02522-01 SHALLOW (WATER DEPTHS 18"-38")

KIT P/N 510-02523-01 MEDIUM (WATER DEPTHS 28"-54")

KIT P/N 510-02524-01 DEEP (WATER DEPTHS 42"-82")

NUMBER	PART NUMBER	QTY.	DESCRIPTION
1	001-26725-00	2	PIN, SAFETY SNAP – 3/8 X 1.75 SS
2	001-70000-00	2	SOFT GRIP KNOB, 1/2-13 X 1-1/4"
*3	001-70103-00	2	HHCS, 3/8-16 X 3/4" SS
*4	001-70105-00	2	HHCS, 3/8-16 X 1" SS
5	001-70110-00	2	HHCS, 3/8-16 X 1-3/4" 18-8 SS
6	001-70118-00	2	HHCS, 3/8-16 X 3-3/4" 18-8 SS
7	001-70119-00	2	HHCS, 3/8-16 X 4" 18-8 SS
8	001-71017-00	12	FLAT WASHER, 3/8" SAE SS 18-8
9	001-73819-00	2	BHCS, 3/8-16 X 2" 18-8 SS
10	001-76071-00	6	NUT, NYLOCK 3/8-16 ALUM.
11	001-76349-00	2	NUT, 3/8-16 ALUM.
12	001-76350-00	2	NUT, 1/2-13 ALUM.
13	002-00064-00	2	BRACKET, W/K BRACE
14	002-00134-00	2	CONNECT, QUICK ATT. SCTNL. SAFETY
15	002-00321-00	2	PAD, SECTIONAL SAND – 12"
16	002-03305-00	2	TUBE, LEG BRACE – 22.5"
17	002-07037-00	2	SAFETY QC, SCTN'L DOCK
18	110-00323-00	2	ASS'Y, QA & STD. SCTN'L – XX-SHALLOW LEG
19	110-00324-00	2	ASS'Y, QA & STD. SCTN'L – X-SHALLOW LEG
20	110-00325-00	2	ASS'Y, QA & STD. SCTN'L – SHALLOW LEG
21	110-00326-00	2	ASS'Y, QA & STD. SCTN'L – MEDIUM LEG
22	110-00327-00	2	ASS'Y, QA & STD. SCTN'L – DEEP LEG

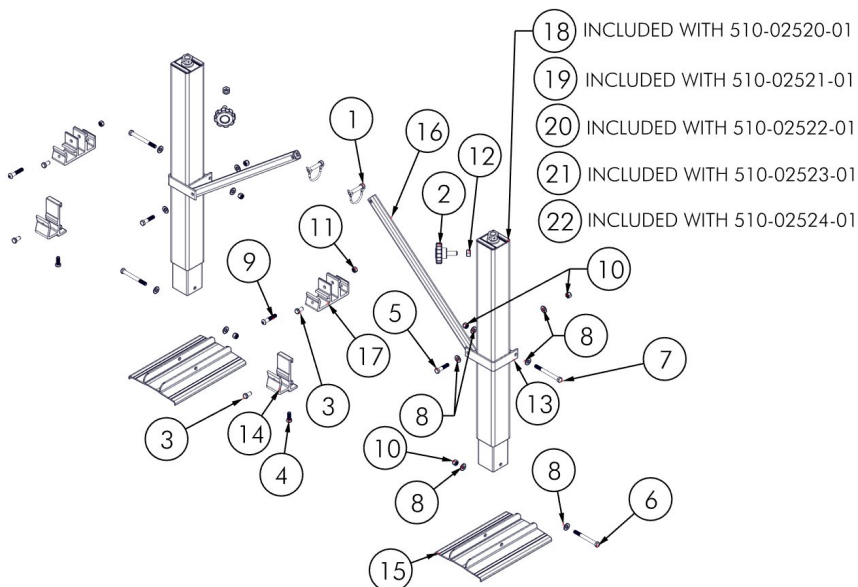

- 18 INCLUDED WITH 510-02520-01
- 19 INCLUDED WITH 510-02521-01
- 20 INCLUDED WITH 510-02522-01
- 21 INCLUDED WITH 510-02523-01
- 22 INCLUDED WITH 510-02524-01

**\*NOTE:**  
**THERE ARE FASTENERS INCLUDED FOR THE INSTALLATION OF ONE PAIR OF SAFETY QUICK CONNECTS ONLY (STANDARD SECTIONAL OR QUICK ATTACH SECTIONAL). REFER TO STEP 5. (ITEMS 3 & 4)**

**NOTE:**  
 LEG BRACKET & BRACE (ITEMS #13 & #16) AND ASSOCIATED HARDWARE IS NOT INCLUDED WITH XX-SHALLOW LEG KIT (P/N 510-02520-01) OR X-SHALLOW LEG KIT (P/N 510-02521-01)

## STEP 1

TURN DOCK UPSIDE DOWN ONTO A SOFT SURFACE (OR USE BLOCKING MATERIAL) TO PROTECT THE DECK SURFACE (FIGURE 1.1). SLIDE A 1/2" ALUMINUM NUT INTO THE TRACK OF EACH LEG POCKET, THEN THREAD A 1/2" X 1" KNOB BOLT IN THROUGH THE LEG POCKET AND INTO THE NUT. DO NOT FULLY TIGHTEN BOLT AT THIS TIME (FIGURE 1.2).

FIGURE 1.1

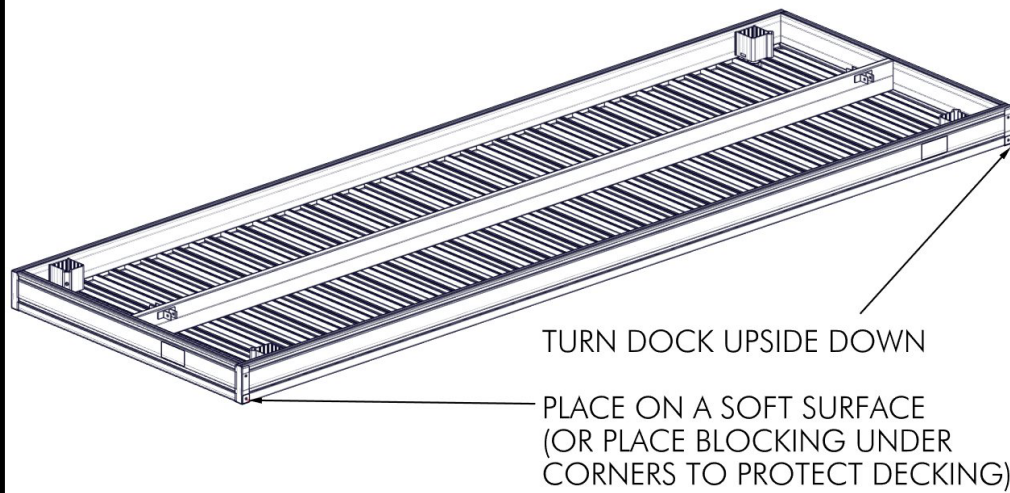
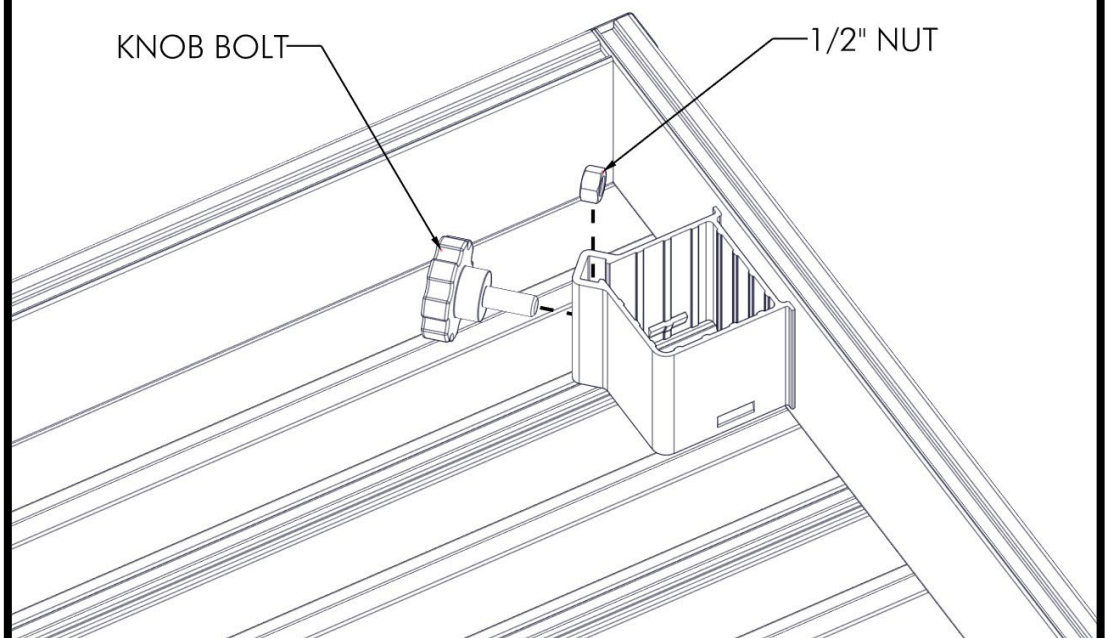

FIGURE 1.2

2X



# LEG PLACEMENTS

SUNDECK/SLIP

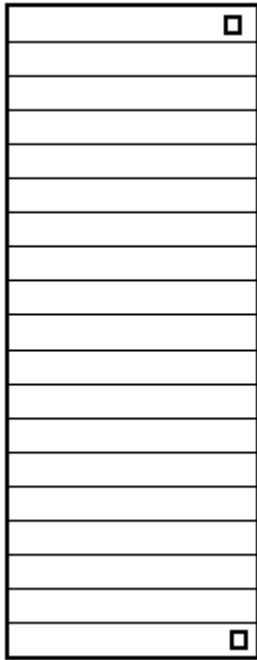

STRAIGHT DOCK

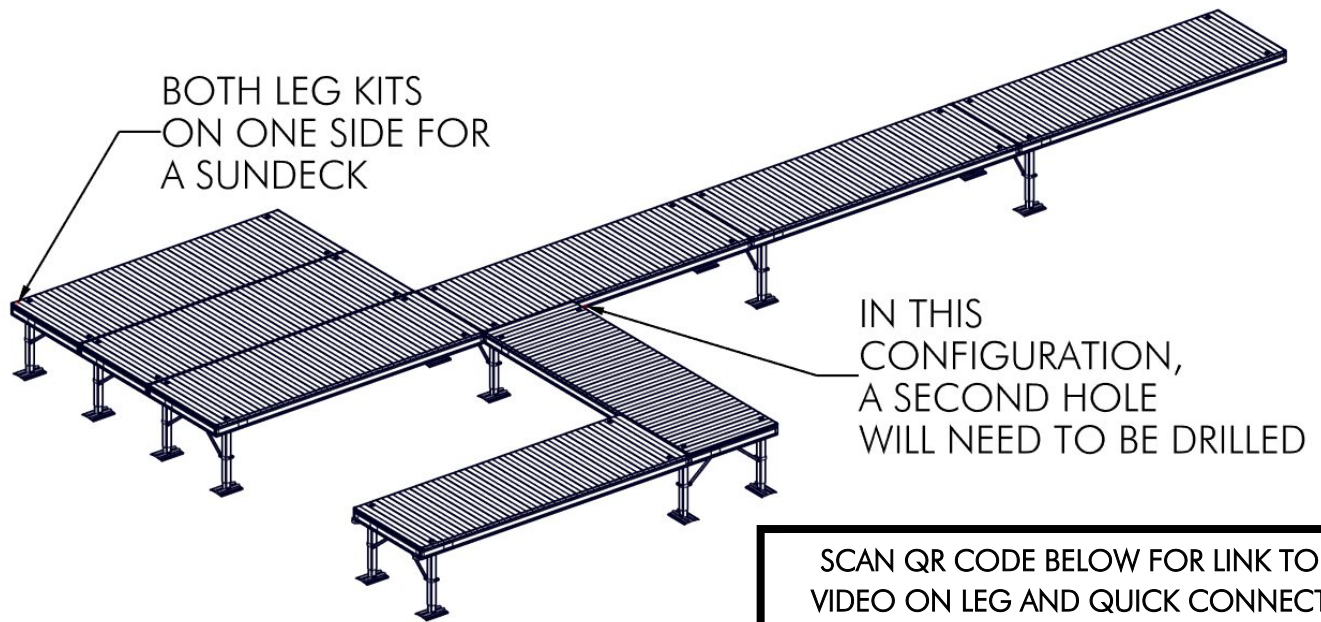
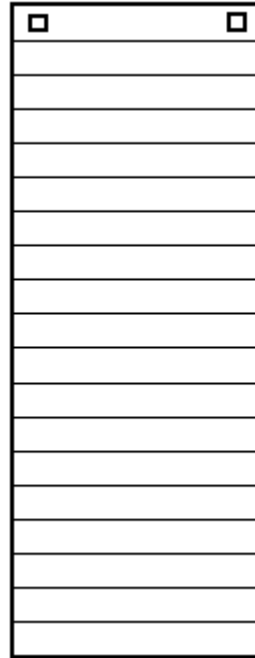

SCAN QR CODE BELOW FOR LINK TO VIDEO ON LEG AND QUICK CONNECT PLACEMENT FOR SUNDECKS AND SLIPS



**LEG PLACEMENTS**

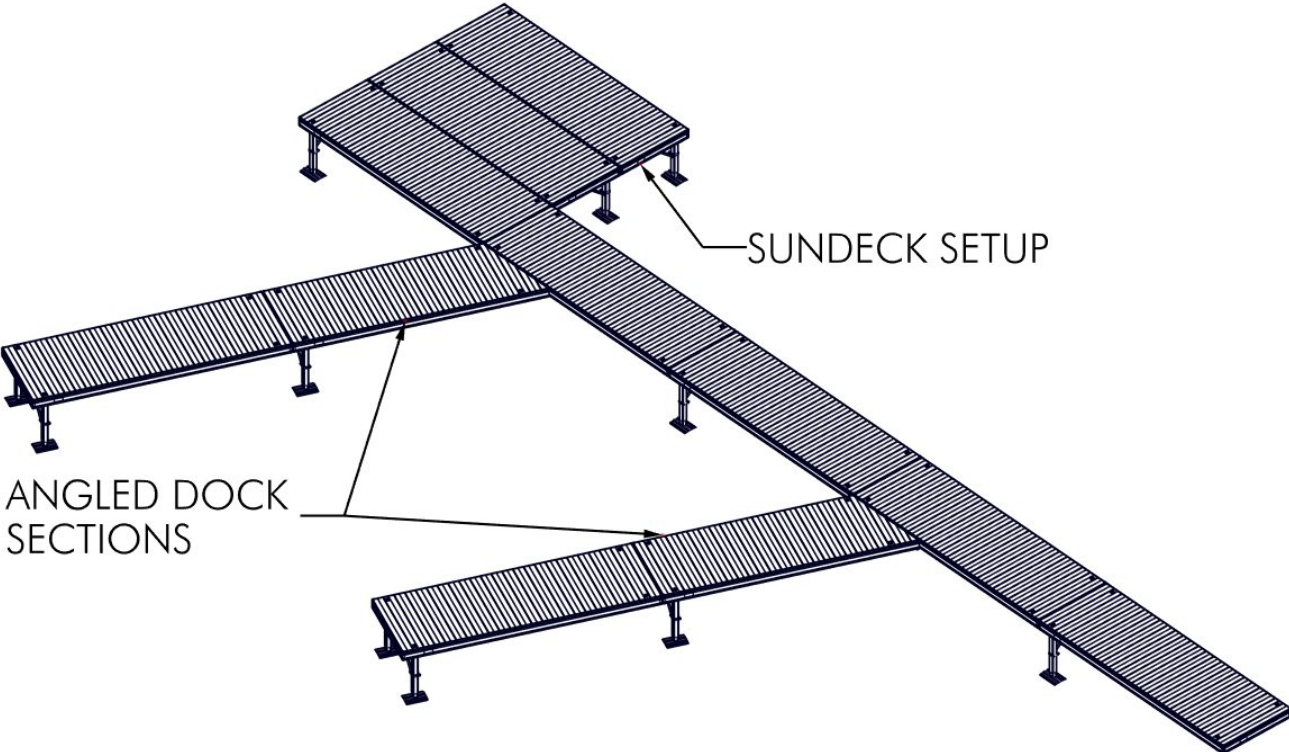

## STEP 2

INSERT A LEG INTO EACH LEG POCKET AS SHOWN. NOTE THE ORIENTATION OF THE SAND PAD MOUNTING BOLT HOLE, WHICH IS PARALLEL TO THE LONG SIDE OF THE DOCK (FIGURE 2.1). ROCKING THE LEG ASSEMBLY WHILE HAND TIGHTENING THE KNOB BOLT WILL HELP ENSURE THAT THE LEG IS SEATED AND THE KNOB BOLT IS ADEQUATELY TIGHTENED. **NOTE: IF THE LEG MOVES IN THE POCKET, THE KNOB BOLT NEEDS TO BE TIGHTENED FURTHER. DO NOT USE ANY TOOLS ON THE KNOB BOLT.** SLIDE A BRACE CLAMP OVER THE LEG WITH THE TAB TOWARD THE CENTER OF THE DOCK AS SHOWN (FIGURE 2.2).

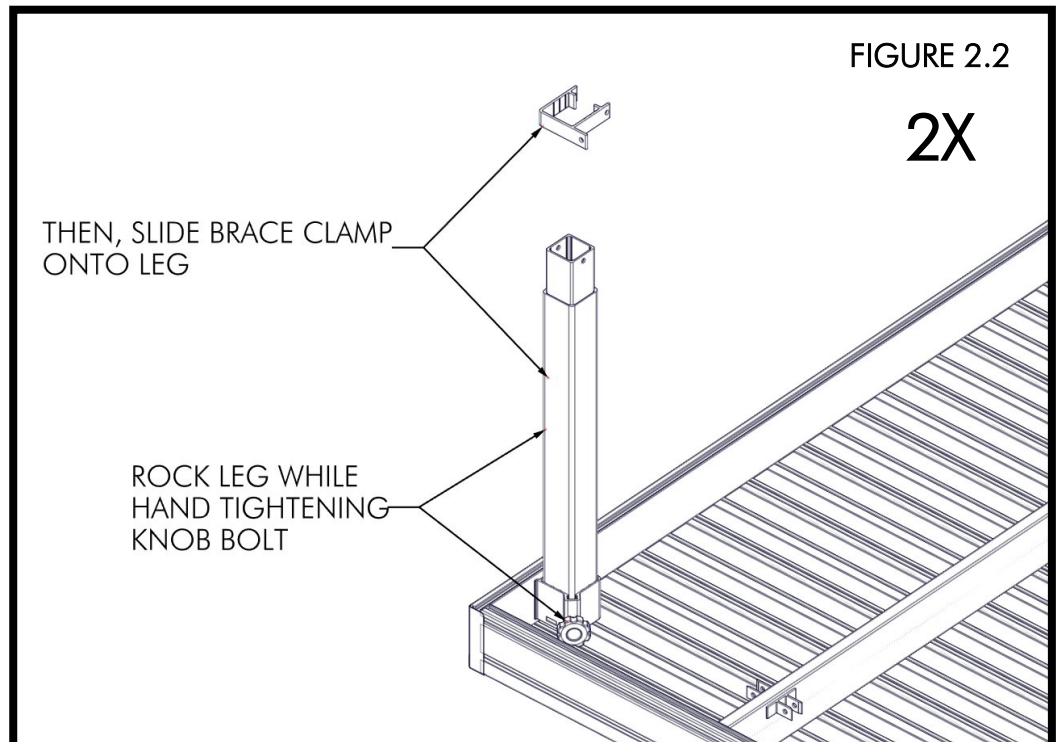
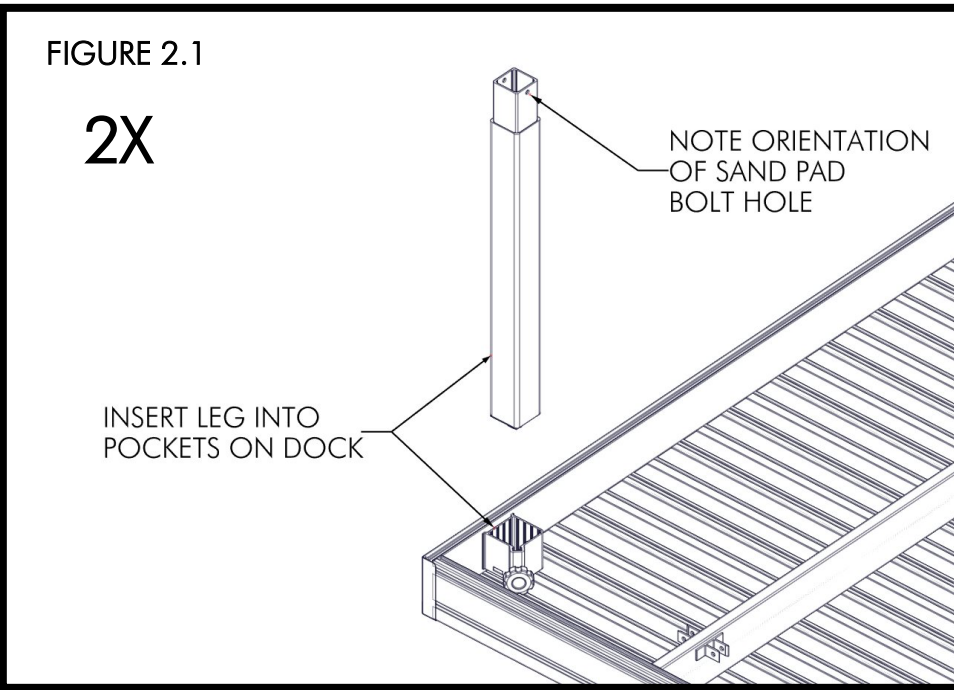

ATTACH THE LEG BRACE CLAMP TO THE LEG USING (1) 3/8" X 4" BOLT, (2) 3/8" WASHERS, AND (1) 3/8" NYLOCK NUT PER LEG. DO NOT TIGHTEN AT THIS TIME (FIGURE 2.3).

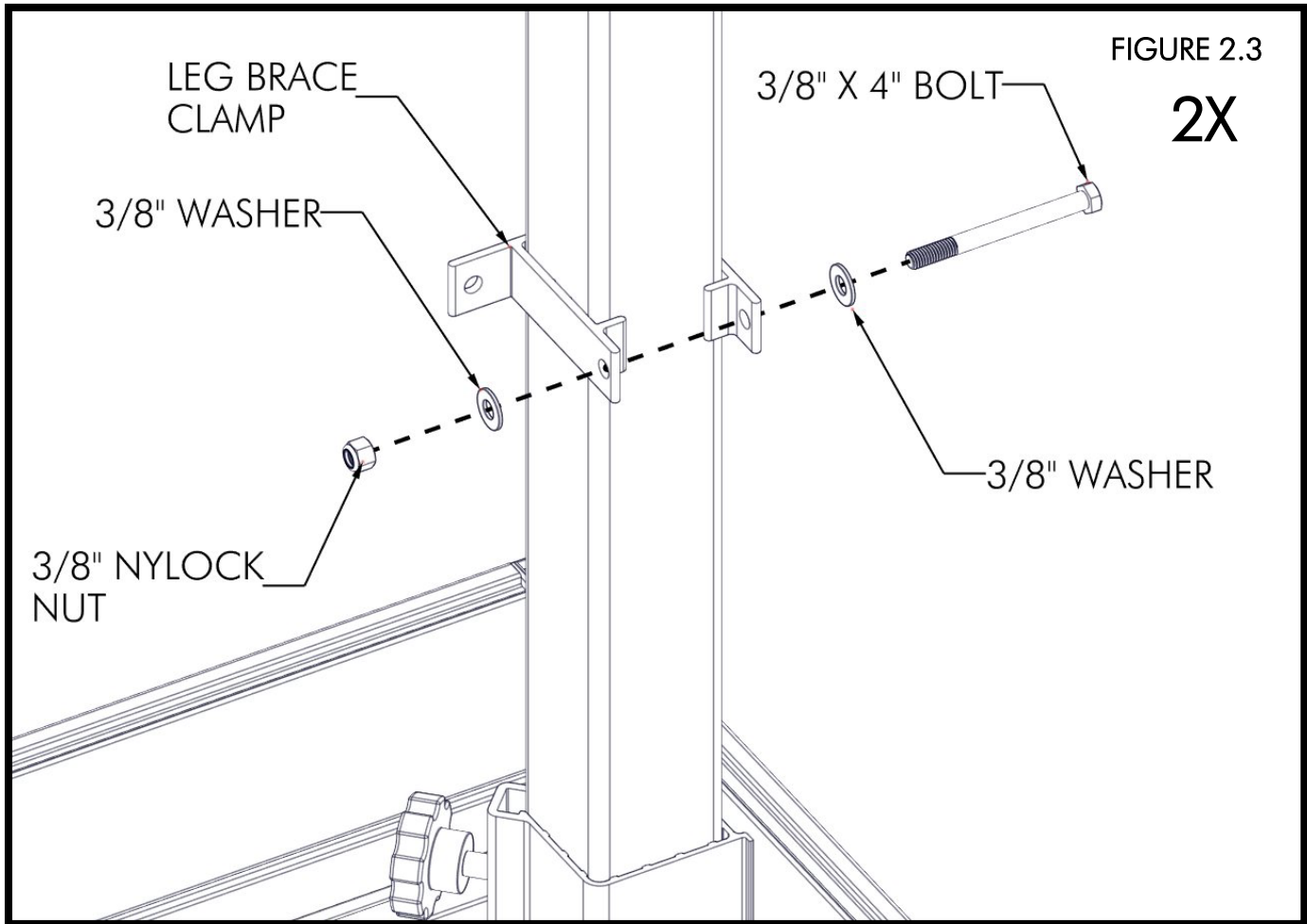

### STEP 3

ATTACH THE (2) 22-1/2" BRACES TO THE CENTER V-BRACE MOUNT USING THE (2) SAFETY SNAP PINS (FIGURE 3.1). FOR ANGLED DOCK SECTIONS, THE BRACES WILL BE PLACED AS SHOWN. OFFSET WILL VARY DEPENDING ON THE STYLE OF ANGLED DOCK (FIGURE 3.1A).

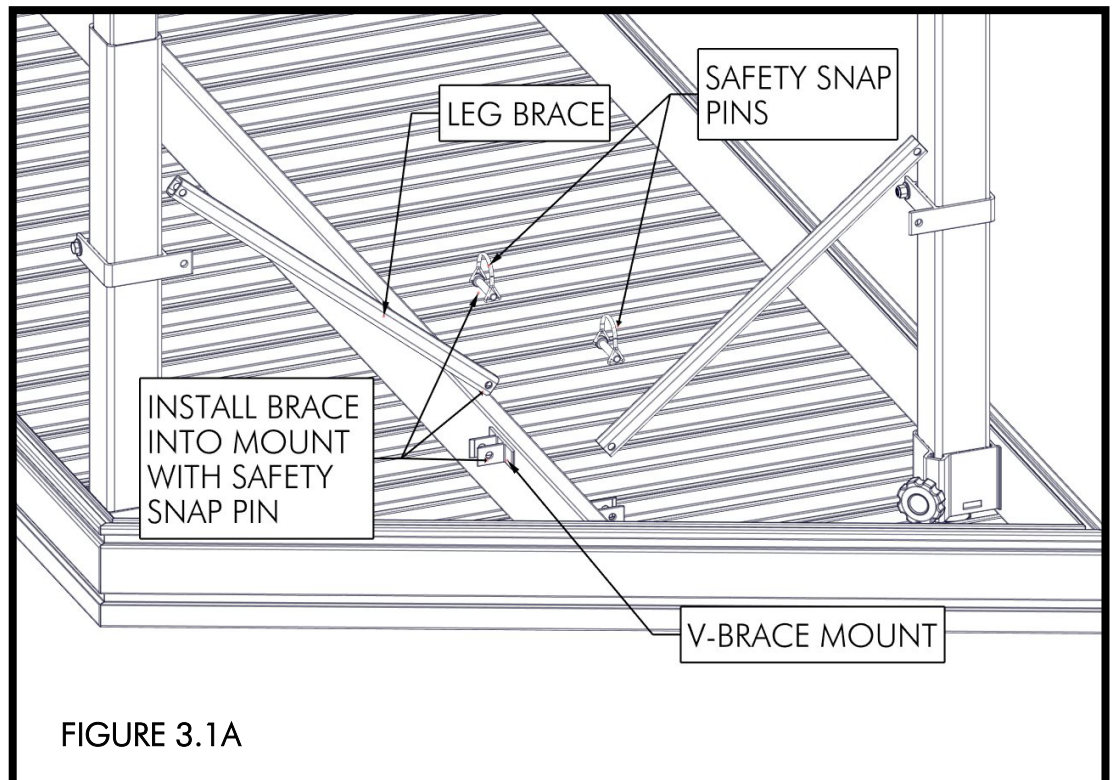
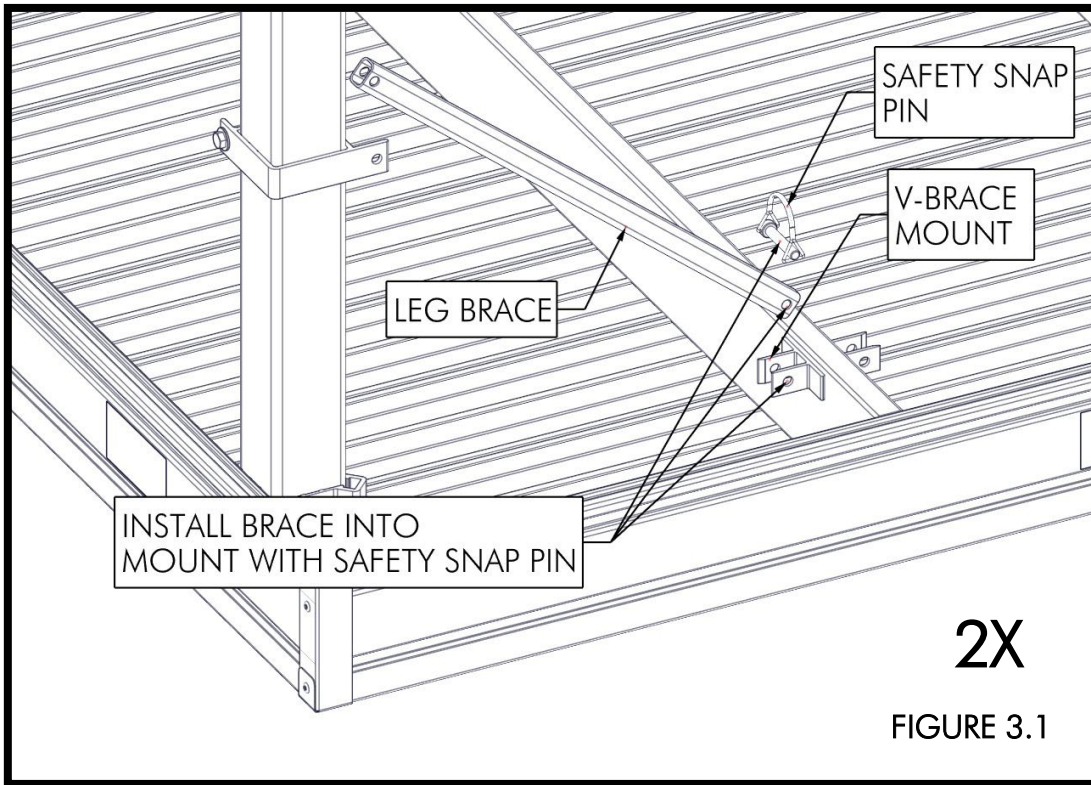



ADJUST THE BRACE BRACKET ON THE DOCK LEG UP OR DOWN AND ATTACH THE BRACES TO THE BRACKET USING (1) 3/8" X 1-3/4" BOLT, (2) 3/8" WASHERS, AND (1) 3/8" NYLOCK NUT PER LEG (FIGURE 3.2).

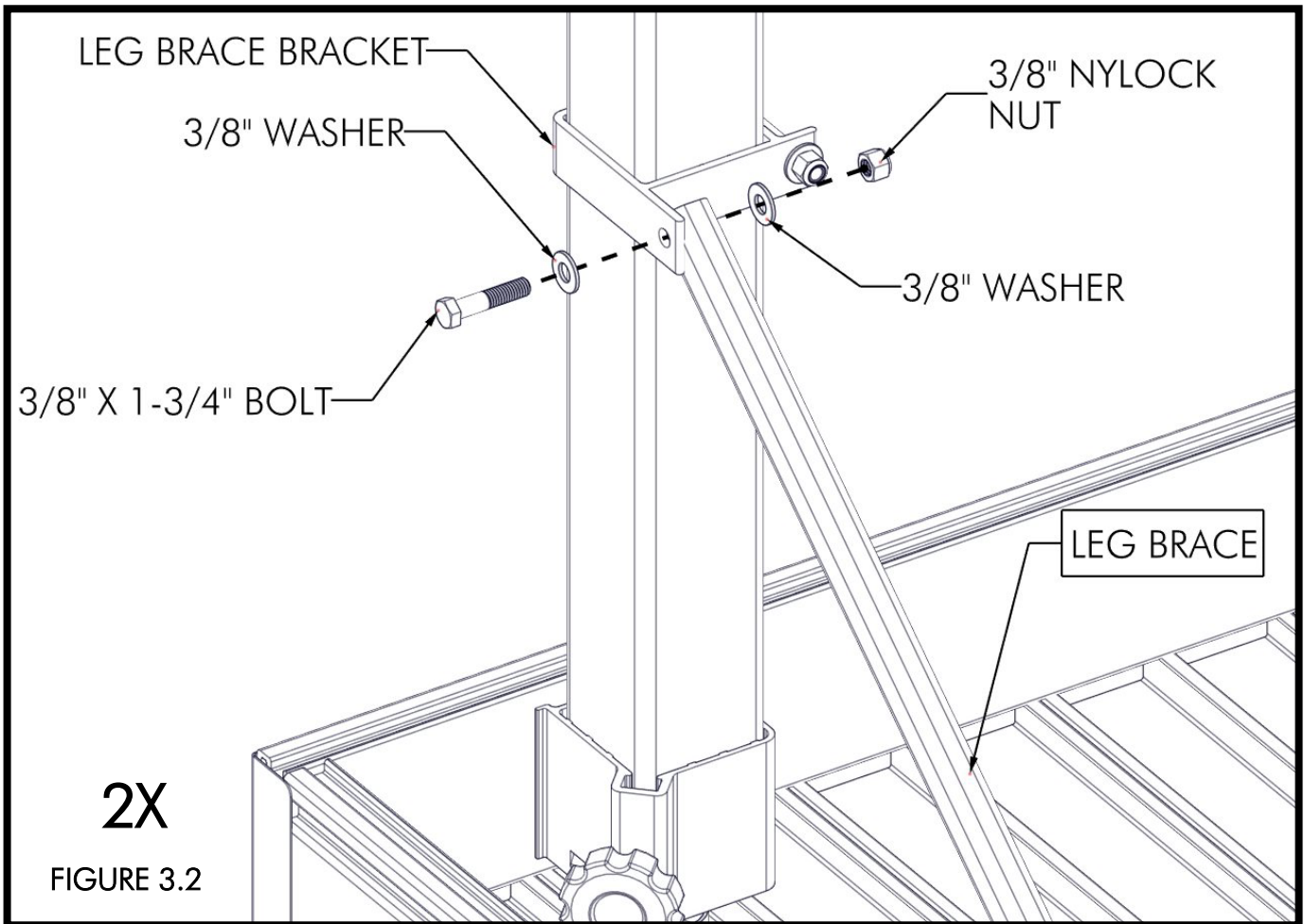

TORQUE TO 10 FT-LB. **NOTE: OVER-TIGHTENING THE FASTENERS WILL CRUSH THE TUBE.**  
TORQUE THE PREVIOUSLY INSTALLED BRACKET FASTENERS FROM STEP 2 TO 20 FT-LB (FIGURE 3.3).

FIGURE 3.3

2X

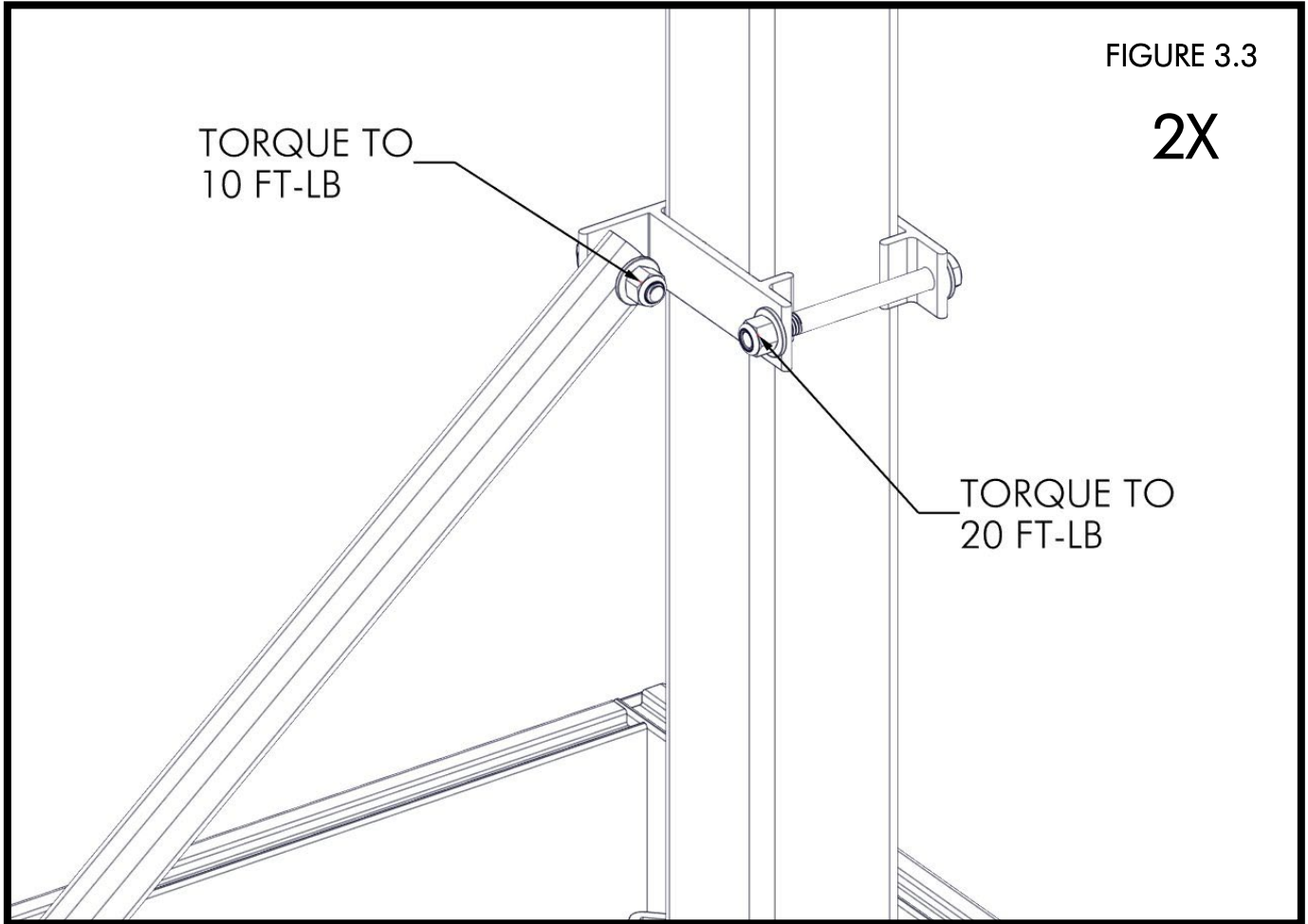

# NOTE

AS OF SEPT. 2017, V-BRACES ARE WELDED TO DOCK SECTIONS AND DO NOT NEED TO BE MOUNTED.

PRIOR TO SEPT. 2017, V-BRACES WERE NOT WELDED IN AND NEED TO BE MOUNTED. FOR INSTALLING NEW WHEEL KITS ON PRE-SEPT. 2017 DOCKS, KIT #510-02515-00 IS NECESSARY. INSTRUCTIONS FOR THESE OLDER DOCKS IS BELOW.

## V-BRACE INSTALLATION FOR DOCKS MANUFACTURED PRIOR TO SEPTEMBER 2017

ATTACH THE (2) CENTER V-BRACE MOUNTS TO EACH SIDE OF THE CENTER FRAME BETWEEN THE TWO LEG POCKETS USING (2) 3/8" X 2" BOLTS AND (2) 3/8" NYLOCK NUTS (FIGURE 3A). FOR A SUNDECK, ATTACH EACH V-BRACE MOUNT TO OPPOSITE ENDS OF THE SAME FRAME BEAM AS SHOWN (FIGURE 3B). TORQUE FASTENERS TO 20 FT-LB.

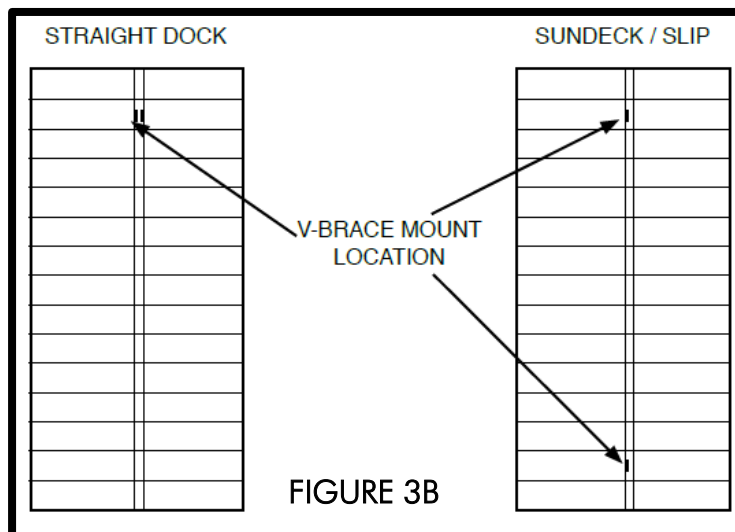
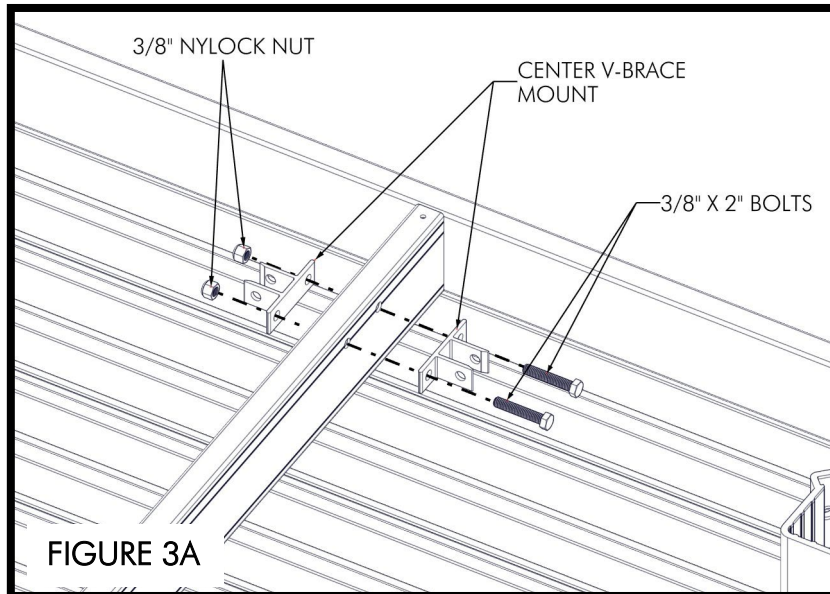

## STEP 4

PLACE A SAND PAD ONTO EACH LEG (FIGURE 4.1). ATTACH SAND PADS TO THE DOCK LEGS USING (1) 3/8" X 3-3/4" BOLT, (2) 3/8" WASHERS, AND (1) 3/8" NYLOCK NUT PER LEG (FIGURE 4.2). TORQUE TO 5 FT-LBS (FIGURE 4.3).

FIGURE 4.1

2X

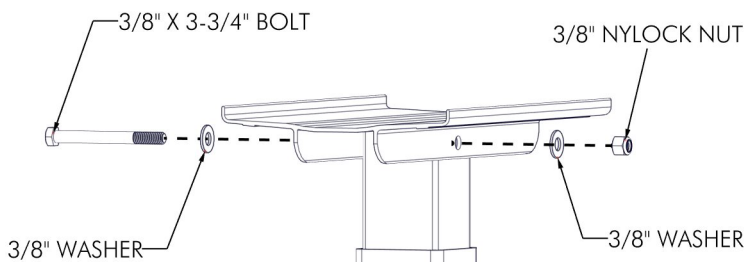
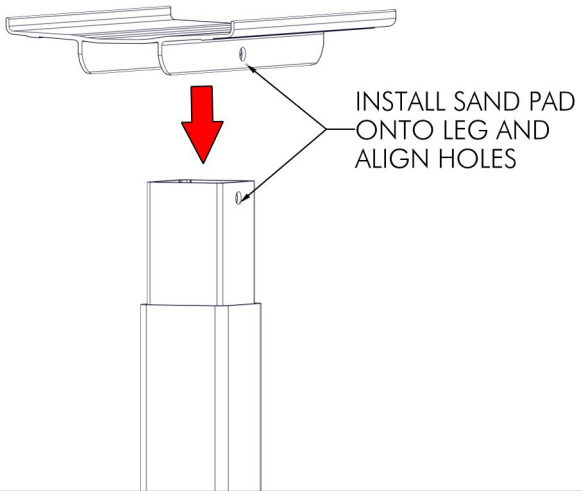

2X

FIGURE 4.2

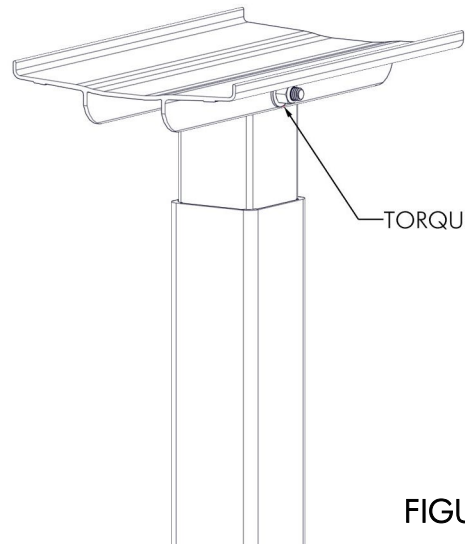

2X

FIGURE 4.3

## STEP 5 – STANDARD SECTIONAL DOCKS

TURN DOCK RIGHT SIDE UP (FIGURE 5.1). QUICK CONNECTS HAVE TWO DIFFERENT SIDES TO ACCOMMODATE STRAIGHT LINED DOCKS/SHORE END RAMPS AND SUNDECK/SLIPS. IF ANOTHER SECTION IS TO BE ADDED TO THE END OF THE DOCK, ATTACH THE SAFETY QUICK CONNECTS TO THE LEG KIT END OF THE DOCK SECTION USING (2) 3/8" X 2" BUTTON HEAD BOLTS AND (2) 3/8" NUTS. **NOTE THE ORIENTATION OF THE QUICK CONNECT.** START A 3/8" X 3/4" BOLT INTO EACH SAFETY CONNECT. DO NOT TIGHTEN, AS THE NEXT DOCK SECTION TO BE PLACED INTO BRACKET (FIGURE 5.2). FOR SUNDECK AND SLIP APPLICATIONS, REFER TO THE NEXT PAGE. TORQUE TO 20 FT-LB (FIGURE 5.3).

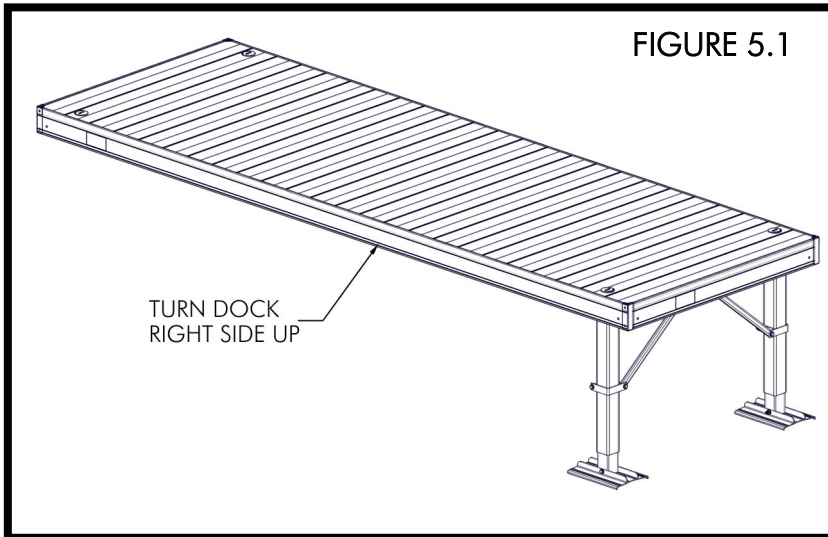

**NOTE:**  
THERE ARE FASTENERS INCLUDED FOR THE INSTALLATION OF ONE PAIR OF SAFETY QUICK CONNECTS ONLY. FOR STANDARD SECTIONAL DOCKS, ONLY THE 3/8" X 3/4" BOLTS ARE USED.

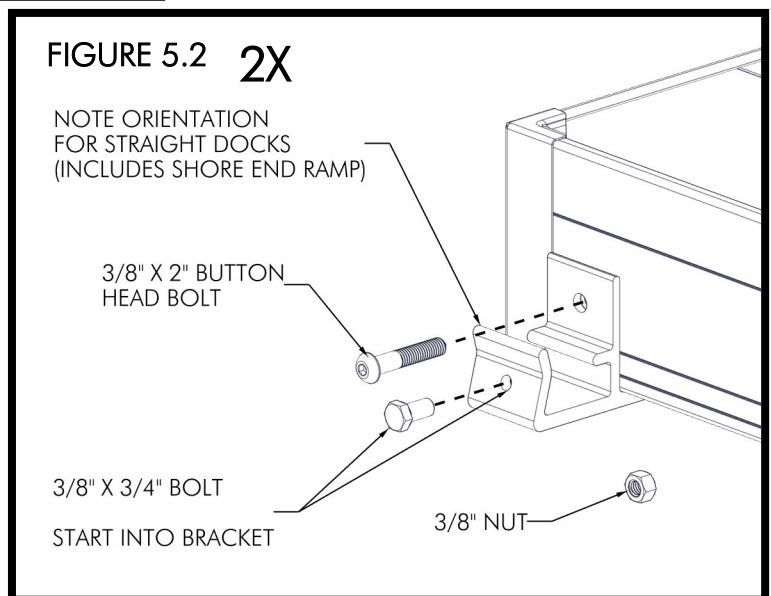
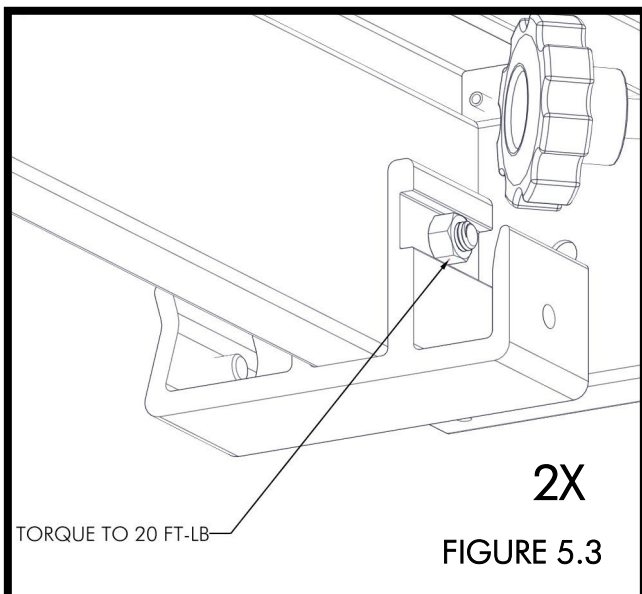

## STEP 5 – STANDARD SECTIONAL DOCKS (CONTINUED)

PLACE NEXT DOCK SECTION INTO SAFETY CONNECT (FIGURE 5.4). TORQUE BOLTS TO 8 FT-LBS (FIGURE 5.5).

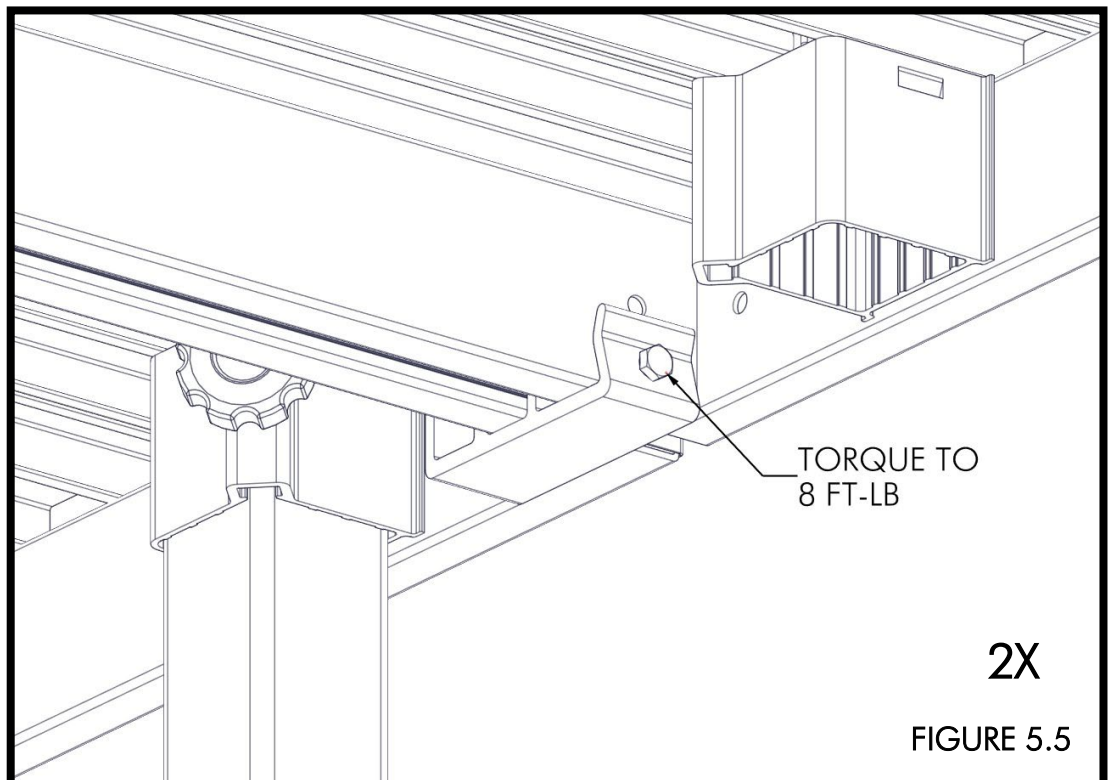
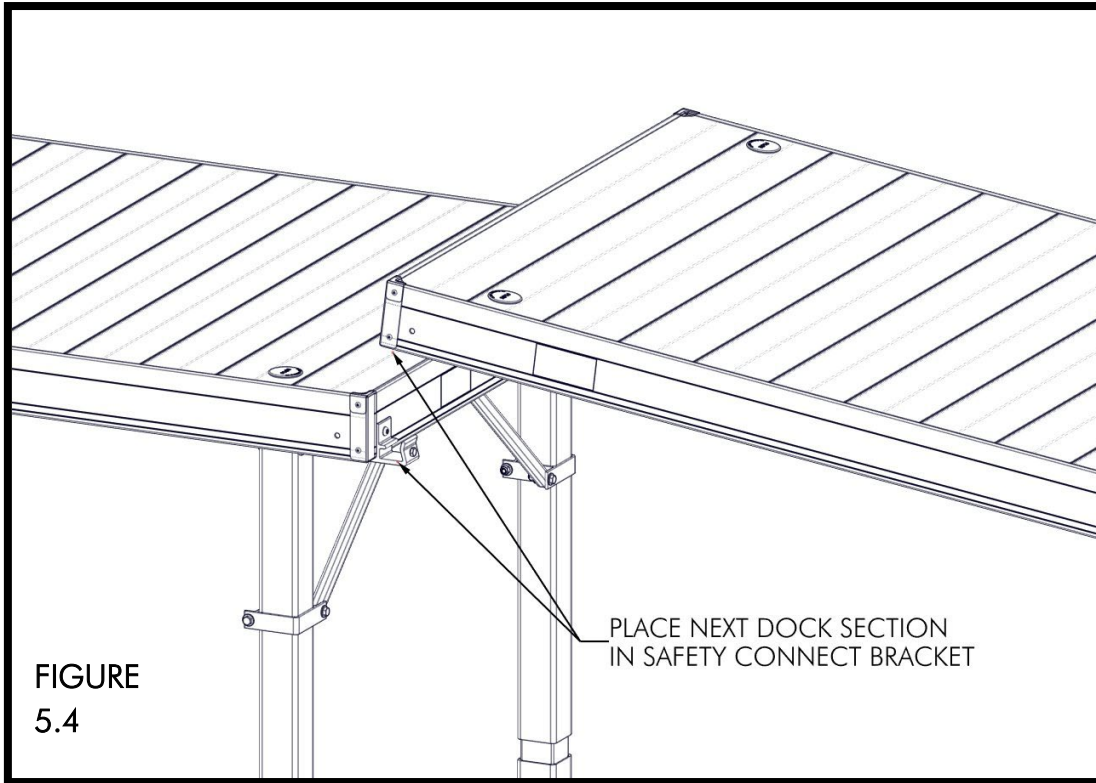

## STEP 5 – STANDARD SECTIONAL DOCKS (CONTINUED)

FOR SUNDECK AND SLIP APPLICATIONS, THE QUICK CONNECT MUST BE POSITIONED AS SHOWN (FIGURE 5.6). **WARNING: INCORRECT ORIENTATION OF THE QUICK CONNECTS WILL PRODUCE A LARGE GAP BETWEEN THE TWO DOCK SECTIONS AND CREATE A POSSIBLE PINCH HAZARD IF THE DOCK SECTIONS BECOME OUT OF LEVEL. SUNDECKS ARE GENERALLY MOUNTED ON THE SIDE OF STRAIGHT DOCK. IF THE SUNDECK IS ATTACHED TO THE END OF A DOCK, THE FIRST SUNDECK WILL REQUIRE (3) LEGS (FIGURE 5.7).**

FIGURE 5.6

2X

SUNDECK AND  
SLIP ORIENTATION  
OF QUICK CONNECT

INSTALL BOLT  
IN OTHER SIDE  
OF QUICK CONNECT

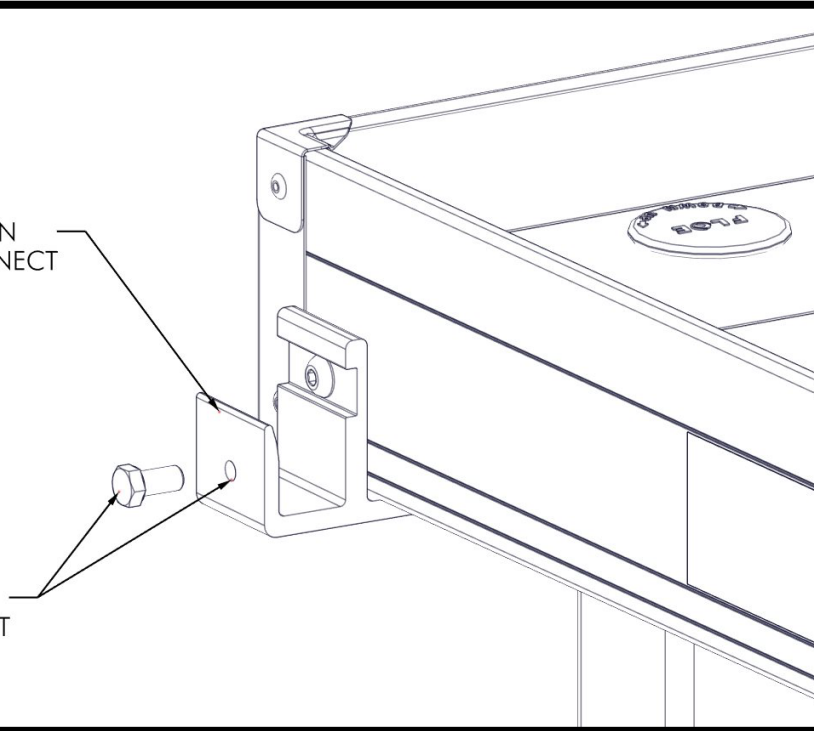

SCAN QR CODE  
BELOW FOR LINK  
TO VIDEO ON LEG  
AND QUICK  
CONNECT  
PLACEMENT FOR  
SUNDECKS AND  
SLIPS



3 LEGS  
REQUIRED  
FOR THIS  
ORIENTATION

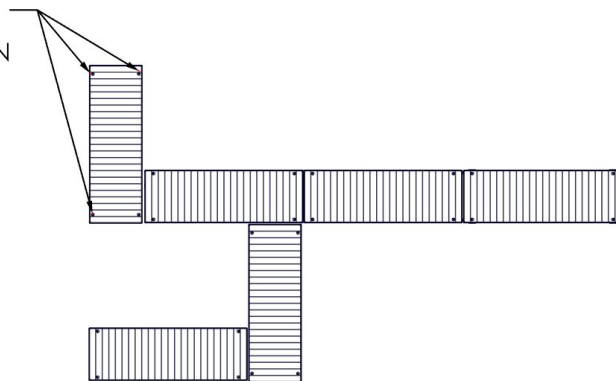
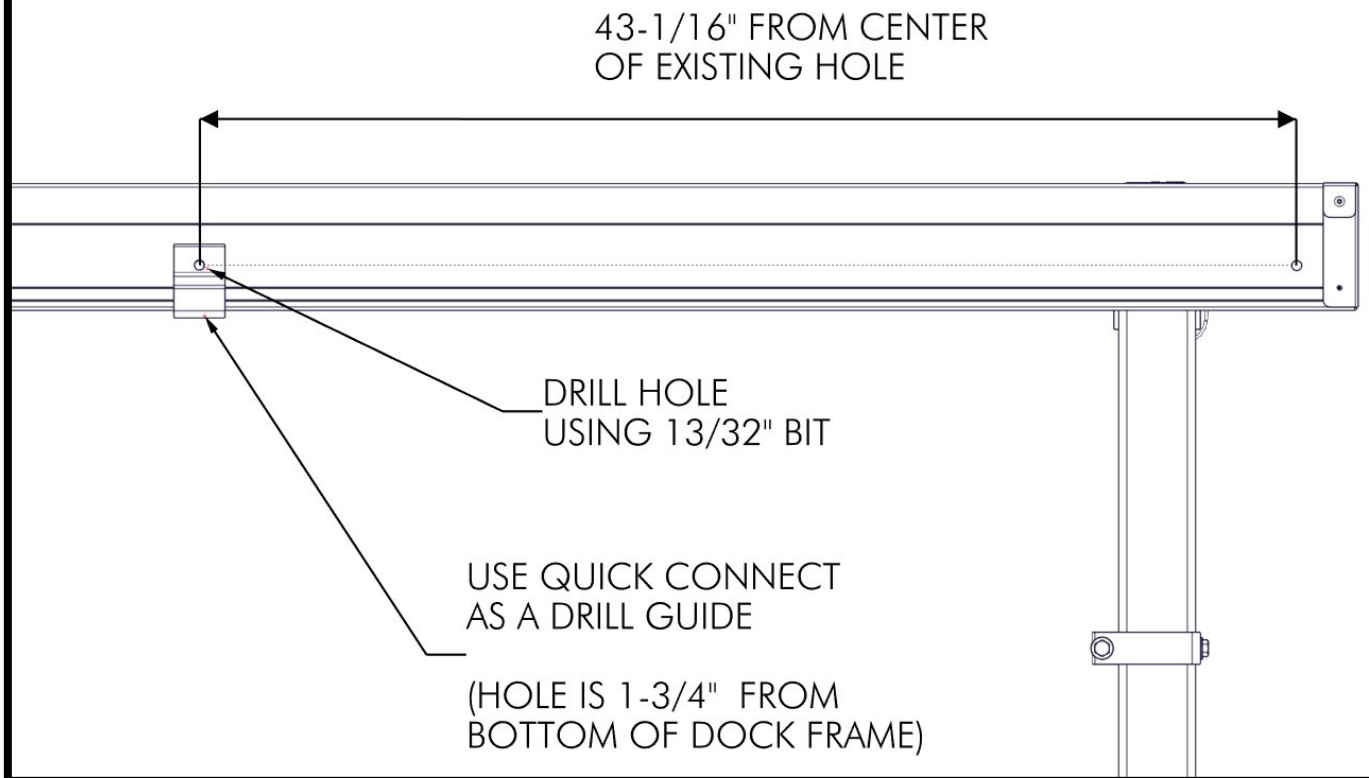

FIGURE 5.7

## STEP 5 – STANDARD SECTIONAL DOCKS (CONTINUED)

FOR SOME STANDARD SECTIONAL DOCK CONFIGURATIONS, IT MAY BE NECESSARY TO DRILL ADDITIONAL HOLES FOR THE QUICK CONNECTS. IN SUCH CASES, THE HOLES ARE POSITIONED 43-1/16" APART AND 1-3/4" UP FROM THE BOTTOM OF THE DOCK FRAME. THE QUICK CONNECT CAN BE USED AS A DRILL GUIDE TO ACHIEVE THE PROPER HOLE HEIGHT. HOLES ARE DRILLED USING A 13/32" DRILL BIT (FIGURE 5.8).

FIGURE 5.8





## STEP 5 – QUICK ATTACH SECTIONAL DOCKS

IF ATTACHING ANOTHER DOCK SECTION, INSERT THE QUICK ATTACH SAFETY CONNECTS INTO THE DOCK END. INSTALL A 3/8" X 1" BOLT INTO EACH SAFETY CONNECT (FIGURE 5.9). SAFETY CONNECTS SHOULD BE SPREAD APART AS FAR AS POSSIBLE TO KEEP THE JOINING SECTION FROM SHIFTING SIDWAYS. TORQUE BOLTS IN THE BOTTOM OF THE SAFETY CONNECTS TO 6 FT-LB MAXIMUM (FIGURE 5.10).

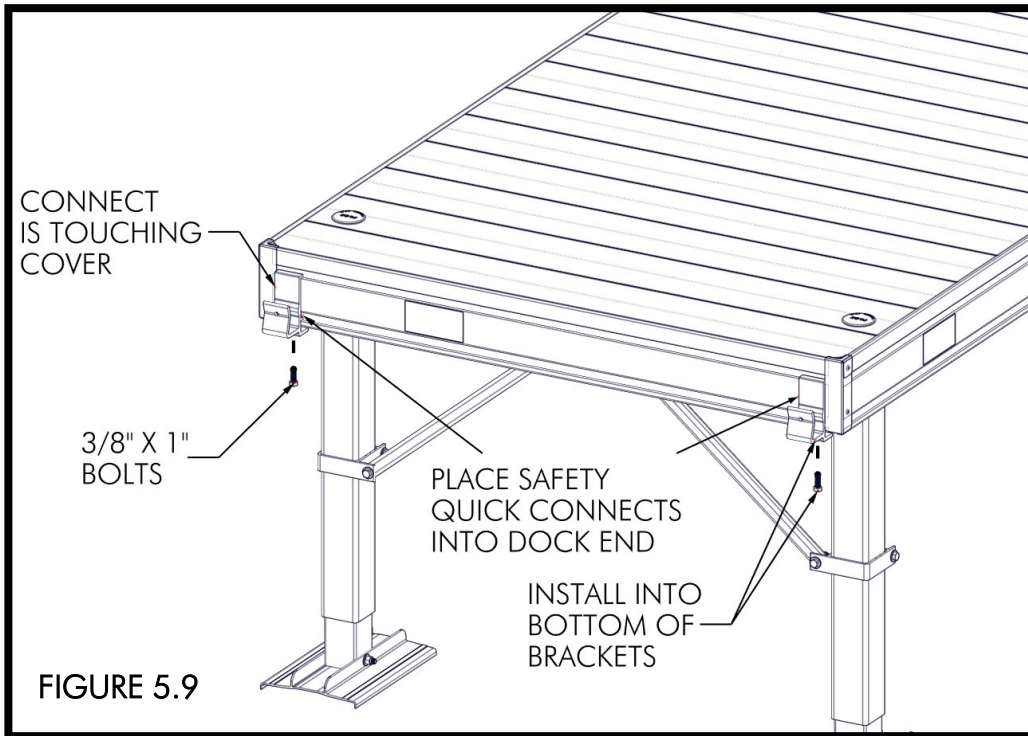

SCAN QR CODE  
BELOW FOR LINK TO  
VIDEO ON QUICK  
CONNECT  
PLACEMENT AND  
DOCK ATTACHMENT



**NOTE:**  
THERE ARE FASTENERS INCLUDED FOR THE INSTALLATION OF ONE PAIR OF SAFETY QUICK CONNECTS ONLY. FOR QUICK ATTACH SECTIONAL DOCKS, BOTH THE 3/8" X 3/4" AND 3/8" X 1" SIZE BOLTS ARE USED.

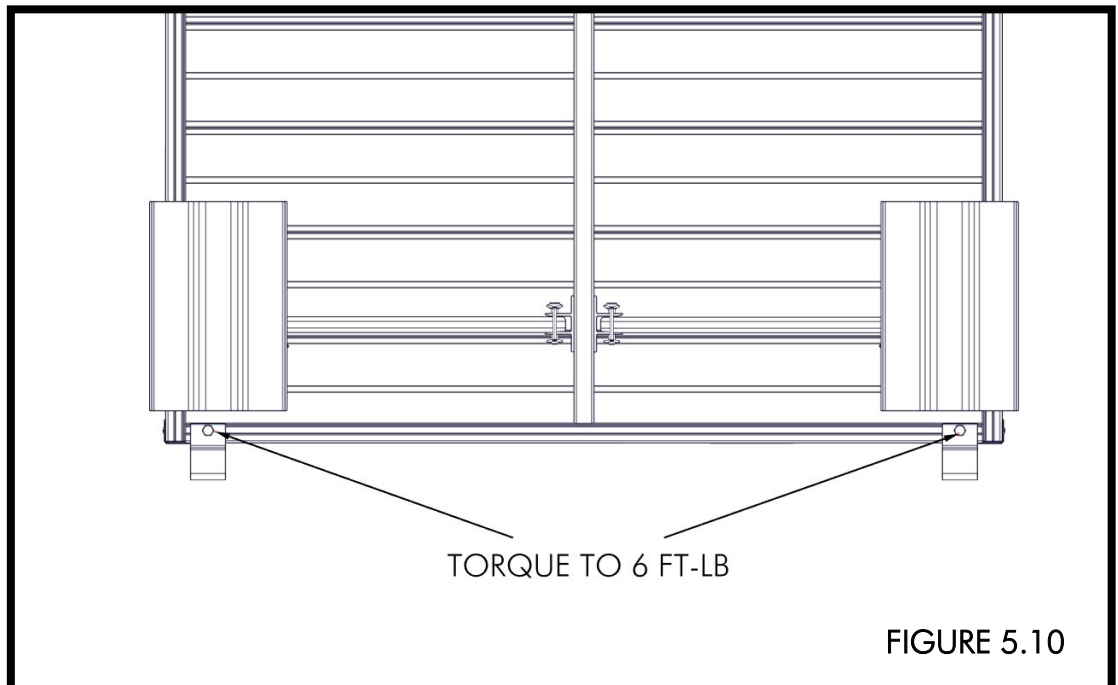

## STEP 5 – QUICK ATTACH SECTIONAL DOCKS (CONTINUED)

FOR ATTACHING SECTIONS TO THE SIDE OF THE DOCK, POSITION THE CONNECTS APPROXIMATELY 46-1/8" APART (FIGURE 5.11). START A 3/8" X 3/4" BOLT INTO EACH SAFETY CONNECT. DO NOT TIGHTEN, AS THE NEXT DOCK SECTION TO BE PLACED INTO BRACKET (FIGURE 5.12).

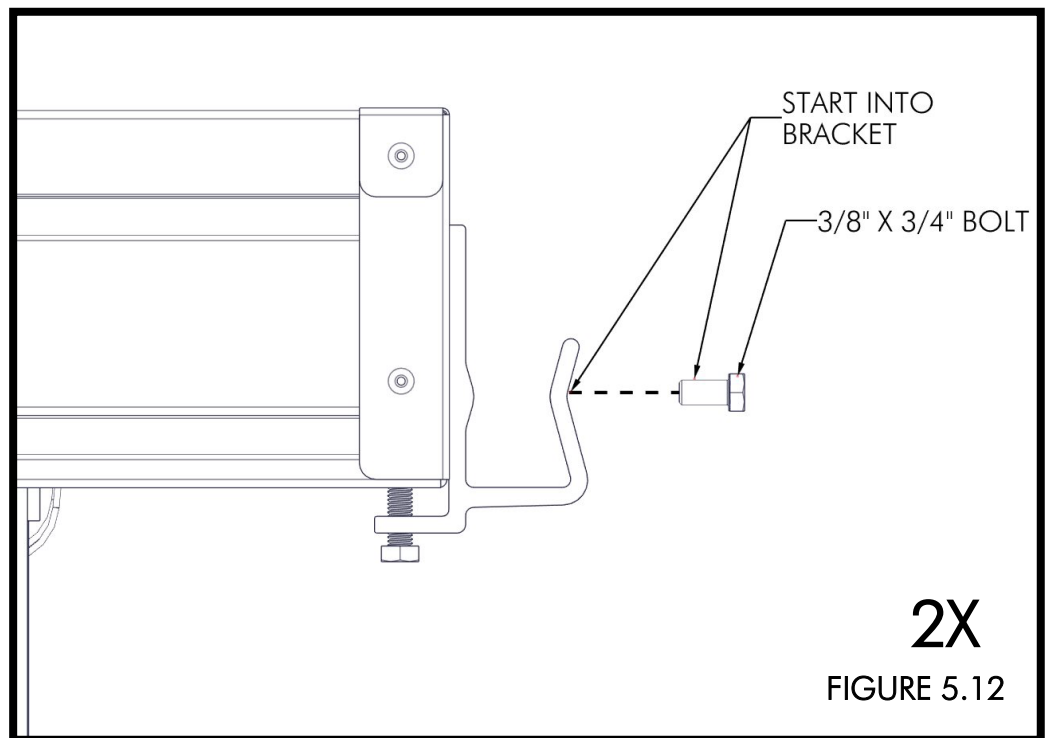
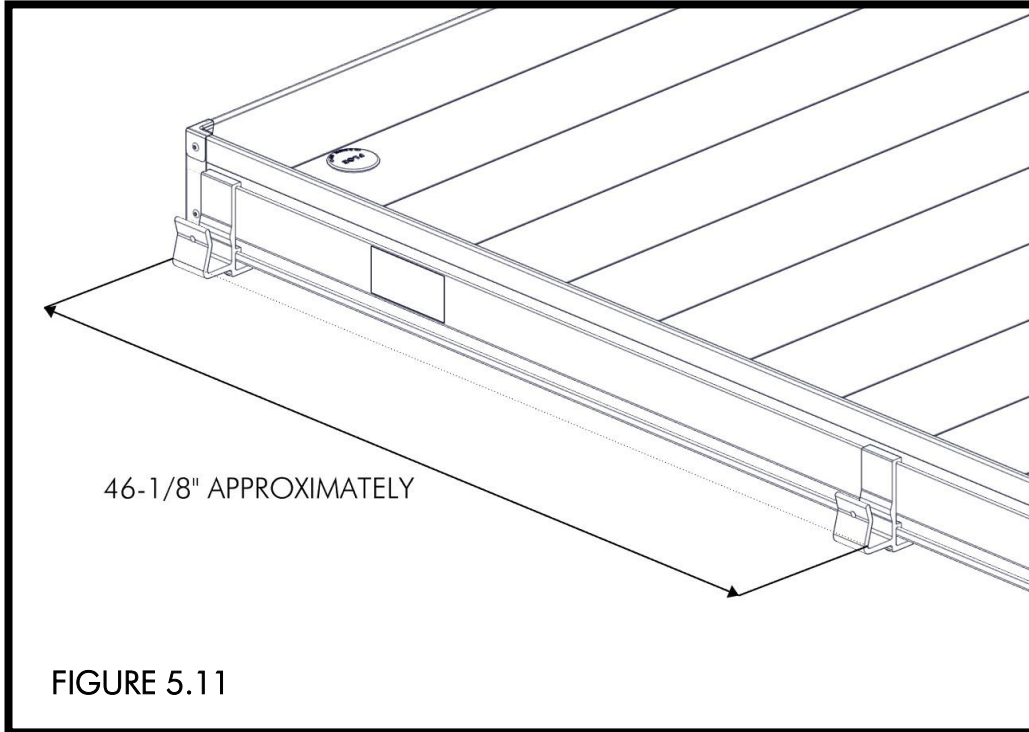

## STEP 5 – QUICK ATTACH SECTIONAL DOCKS (CONTINUED)

PLACE NEXT DOCK SECTION INTO SAFETY CONNECT (FIGURE 5.13). TORQUE BOLTS TO 8 FT-LBS (FIGURE 5.14).

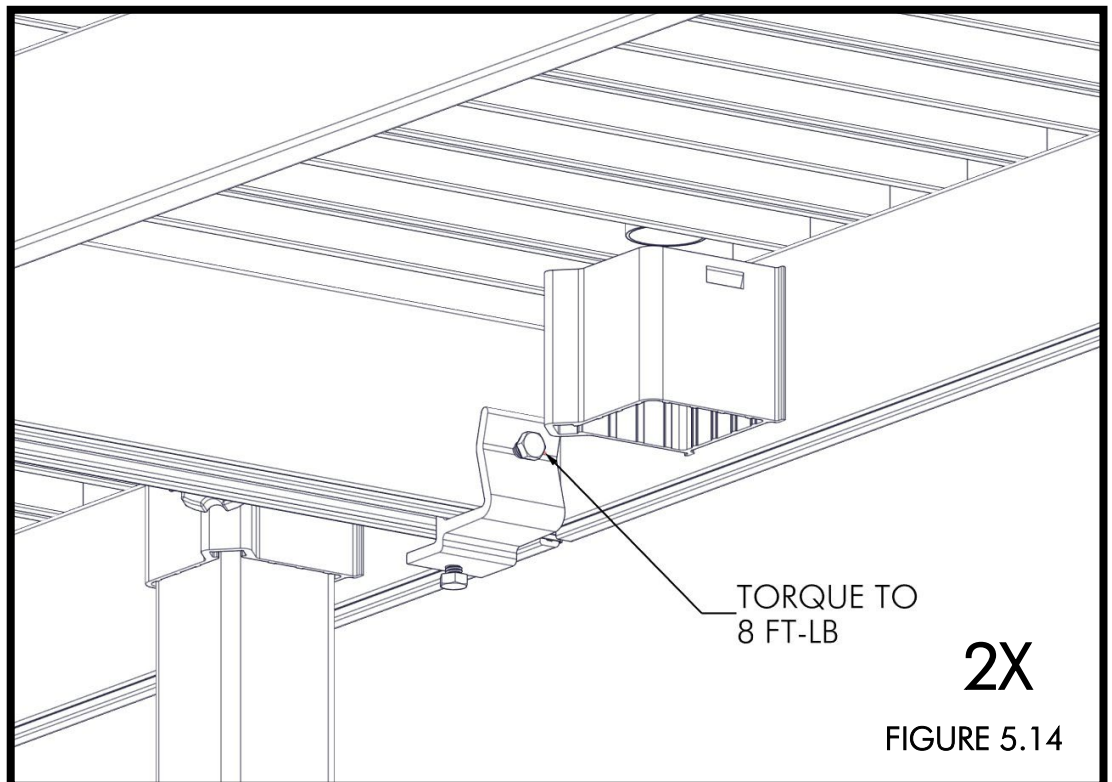
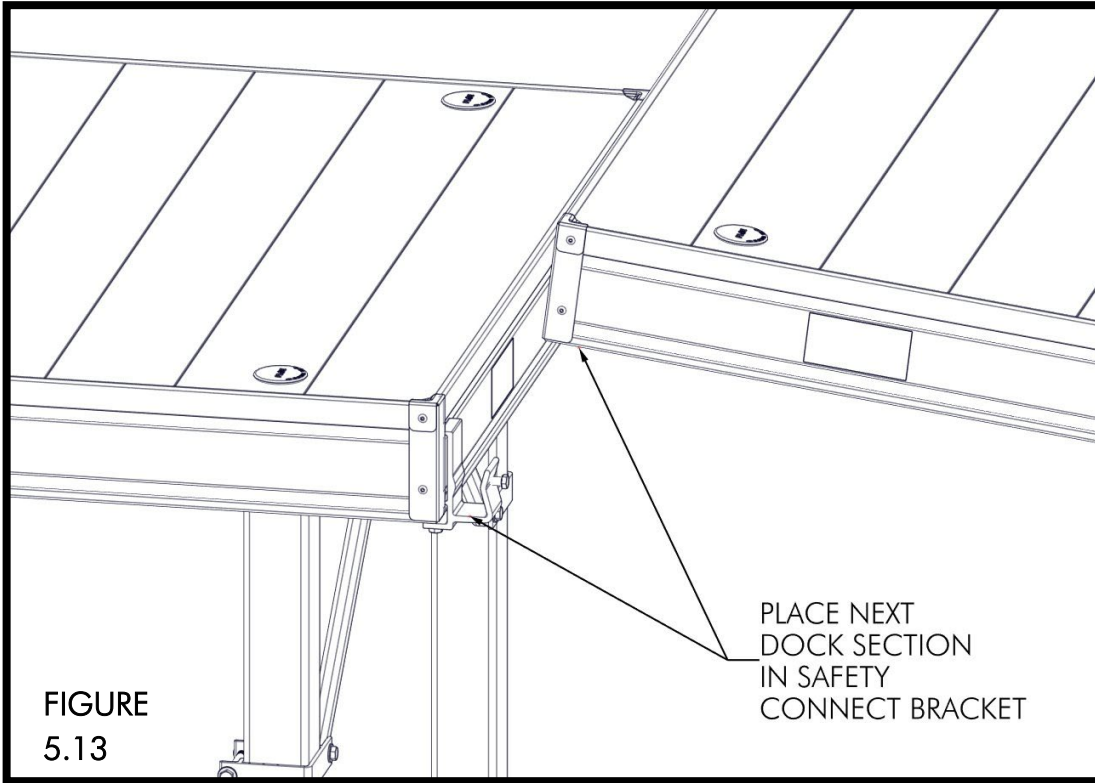

## LEVELING THE DOCK

FIRST, REMOVE THE CAPS INSTALLED ON THE DOCK COVERING THE LEG ADJUSTING NUT. USING A FLOE SPEED WRENCH OR 1-1/8" SOCKET AND DRILL, ADJUST THE HEIGHT OF THE DOCK SO THE BOTTOM FRAME OF THE DOCK IS APPROXIMATELY 16" ABOVE THE WATER. **\*SEE NOTE ON THE NEXT PAGE.** TURN THE DOCK ADJUSTING NUT ON THE TOP OF THE DOCK CLOCKWISE TO LOWER THE DOCK AND COUNTERCLOCKWISE TO RAISE THE DOCK. USE A LEVEL TO MAKE SURE ALL DOCK SURFACES ARE LEVEL (FIGURE 6.1). ONCE THE DOCK IS SET IN PLACE AND LEVELED, RE-INSERT THE PLASTIC CAPS IN THE ADJUSTMENT NUT HOLE (FIGURE 6.2).

FIGURE 6.1

2X

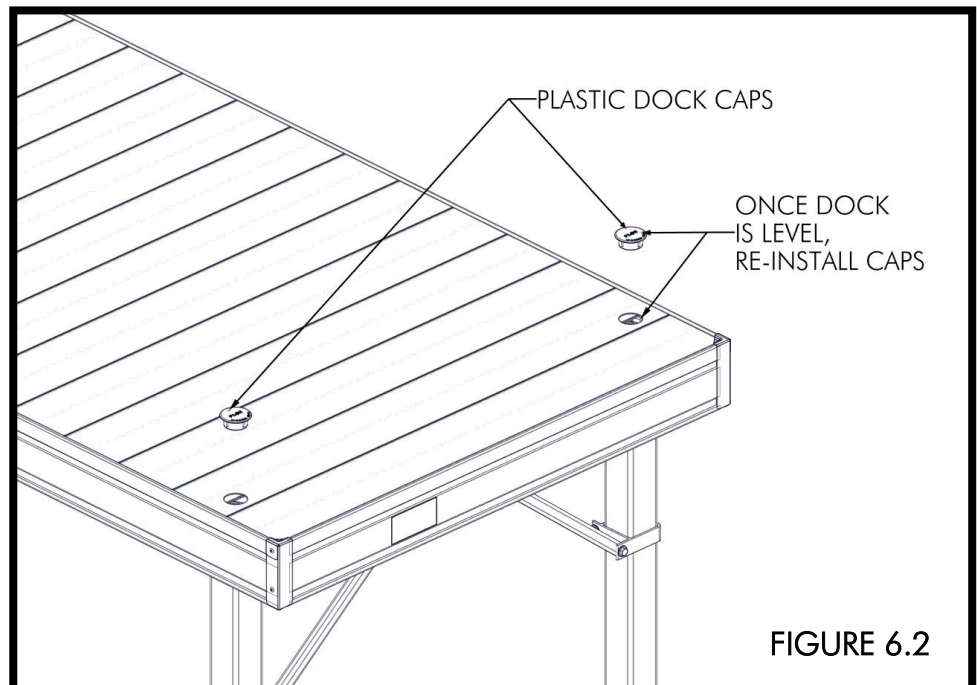
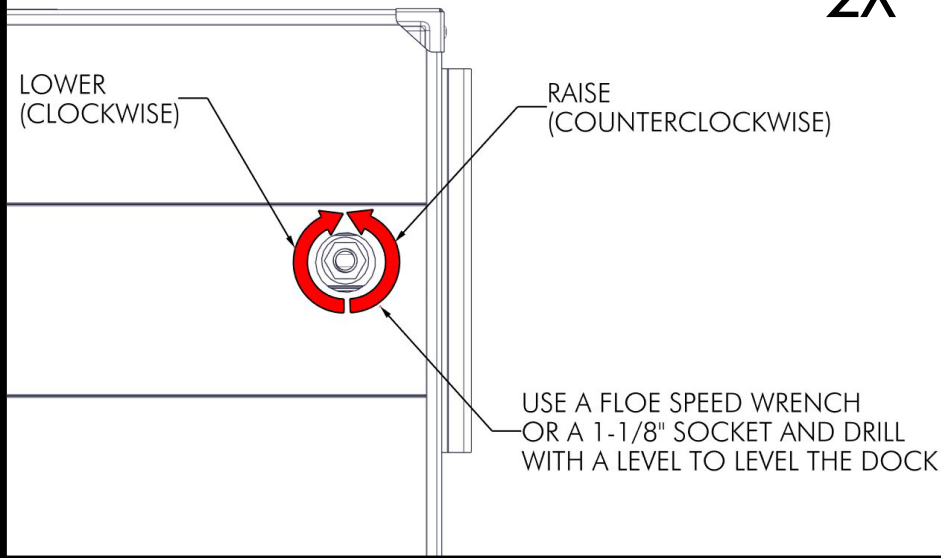

**NOTES**

# **NOTES**

**NOTES**

## WARNINGS



CORDLESS DRILL MAY COME TO A SUDDEN STOP WHEN THE LEG IS FULLY EXTENDED OR RETRACTED.

BE SURE TO HAVE YOUR CORDLESS DRILL IN CLUTCH MODE WHEN ADJUSTING THE LEGS. USE OF A CORDED DRILL MAY CAUSE ELECTROCUTION. FAILURE TO USE DRILL IN CLUTCH MODE MAY CAUSE INJURY TO YOUR HAND OR ARM.



NEVER ADJUST YOUR DOCK LEGS WITH AN IMPACT WRENCH. IF YOU CAN NOT TURN THE ADJUSTING NUT, DO NOT FORCE IT – YOU HAVE REACHED THE END OF THE ADJUSTMENT RANGE. DO NOT EXCEED 15 FT-LB. APPLYING TOO MUCH FORCE TO YOUR DOCK LEGS WILL DAMAGE THE MECHANISM.

NOTE:

WE RECOMMEND THAT THE LOWER DOCK FRAME IS A MINIMUM OF 11" ABOVE THE WATER WHEN PROPERLY ADJUSTED. HOWEVER, IF YOU HAVE HIGH WAVE CONDITIONS THAT COMMONLY EXCEED 15", WE RECOMMEND THAT YOU RAISE YOUR DOCK ACCORDINGLY.