

FLOE SHORE END RAMP HINGE KIT FOR FLOATING DOCKS

ASSEMBLY INSTRUCTIONS

P/N 210-05203-00 3' HINGE KIT
210-05204-00 4' HINGE KIT
210-05205-00 5' HINGE KIT
210-05206-00 6' HINGE KIT
210-05208-00 8' HINGE KIT

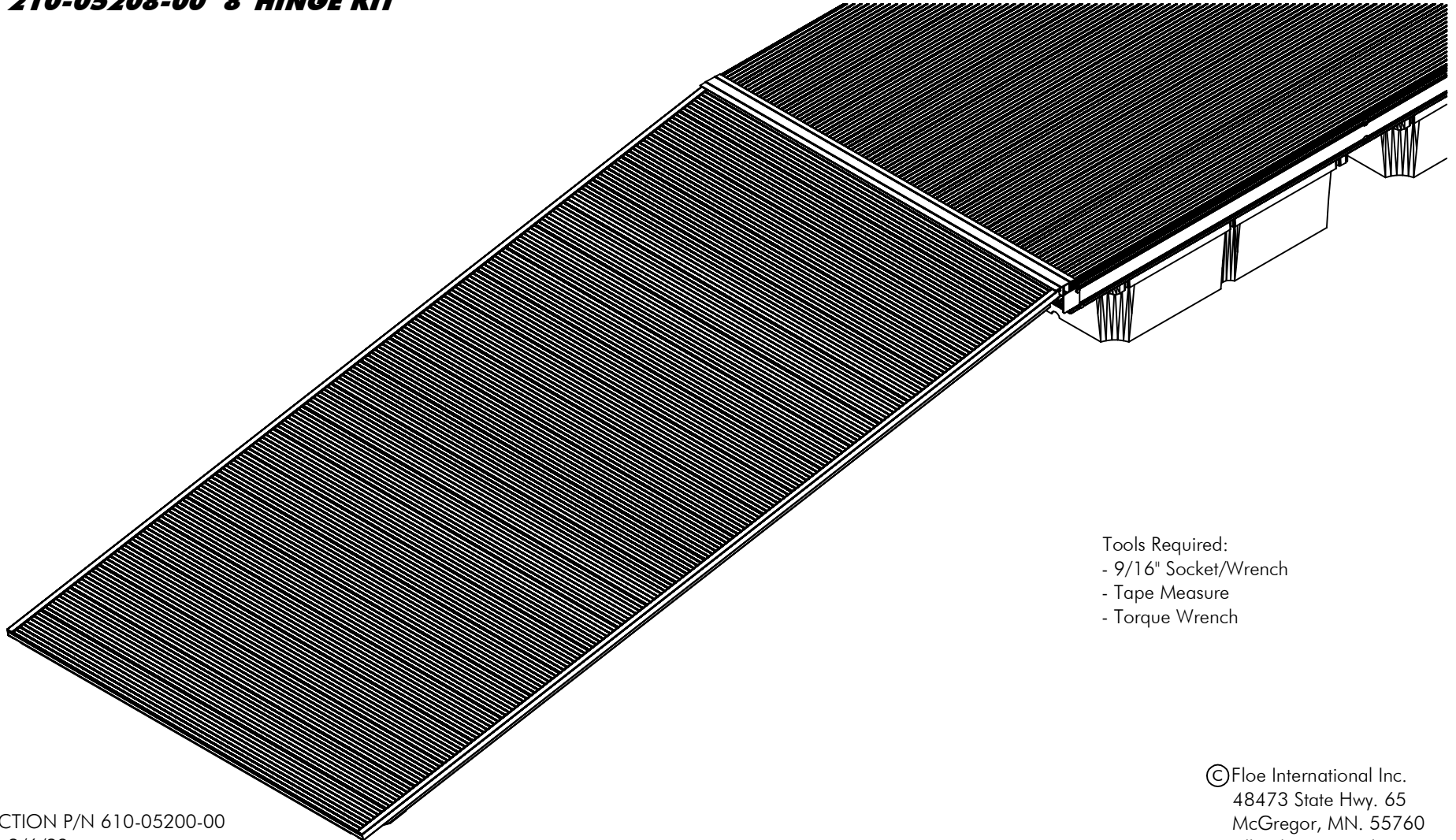

Tools Required:
- 9/16" Socket/Wrench
- Tape Measure
- Torque Wrench

INSTRUCTION P/N 610-05200-00
ISSUED: 2/6/23

Sheet 1 of 4

©Floe International Inc.
48473 State Hwy. 65
McGregor, MN. 55760
All rights reserved

SHORE END RAMP HINGE KIT EXPLODED VIEW

P/N: 210-05203-00 3' HINGE KIT
210-05204-00 4' HINGE KIT
210-05205-00 5' HINGE KIT
210-05206-00 6' HINGE KIT
210-05208-00 8' HINGE KIT

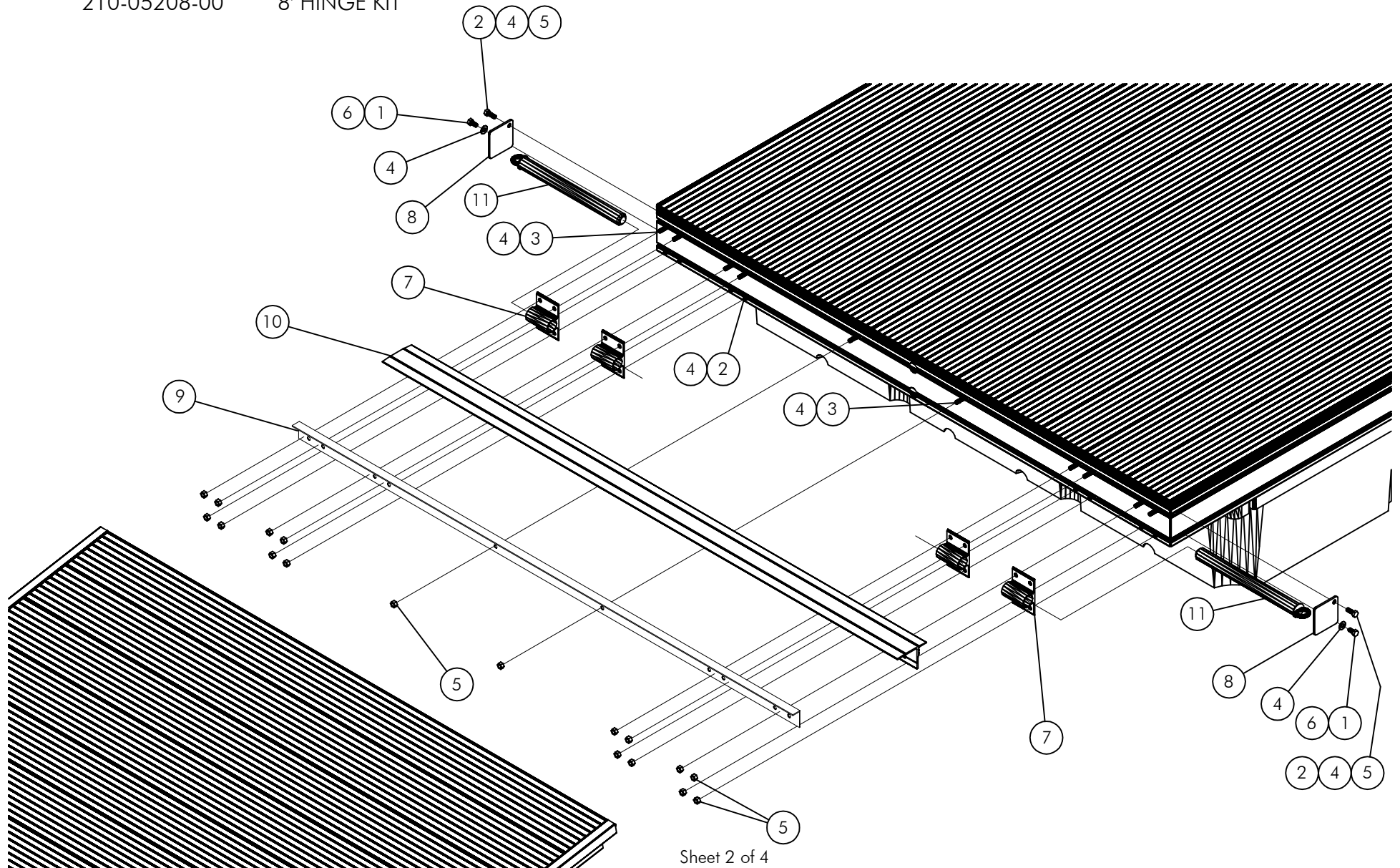

SHORE END RAMP HINGE KIT PARTS LIST FOR FLOATING DOCKS

Item	Part No.	Qty	Description
1	001-70103-00	2	HHCS, 3/8-16 x 3/4" 18-8 SS
2	001-70105-00	10	HHCS, 3/8-16 x 1" 18-8 SS
3	001-70109-00	11	HHCS, 3/8-16 x 1 1/2" 18-8 SS
4	001-71017-00	25	FLATWASHER, 3/8" SAE SS 18-8
5	001-76071-00	21	NUT, NYLOCK 3/8-16 ALUMINUM
6	001-76349-00	2	NUT, 3/8-16 ALUMINUM
7	002-02512-00	4	HINGE, FLOATING DOCK - 3"
8	002-02525-00	2	PLATE, HINGE - FLOATING DOCK
9	SEE CHART	1	PLATE, RAMP TRIM
10	SEE CHART	1	TRIM, RAMP
11	110-00028-00	2	ASSEMBLY, HINGE ROD

HARDWARE KIT FOR ALL SIZES OF RAMPS.
THERE MAY BE EXTRA PARTS DEPENDING
ON SIZE OF RAMP.

SHORE END RAMP TRIM CHART		
Ramp Width	Trim P/N	Trim Plate P/N
3'	010-04906-00	002-02546-00
4'	010-04907-00	002-02547-00
5'	010-04908-00	002-02548-00
6'	010-04909-00	002-02549-00
8'	010-04910-00	002-02550-00

STEP 1

- SLIDE REQUIRED AMOUNT OF 3/8 x 1 1/2" BOLTS W/ FLATWASHERS INTO UPPER NUT TRACK. SLIDE (8) 3/8 x 1" BOLTS W/ FLATWASHERS INTO LOWER NUT TRACK. ALIGN 3/8 x 1 1/2" BOLTS WITH HOLES IN TRIM & TRIM PLATE. SEE FIG. 1

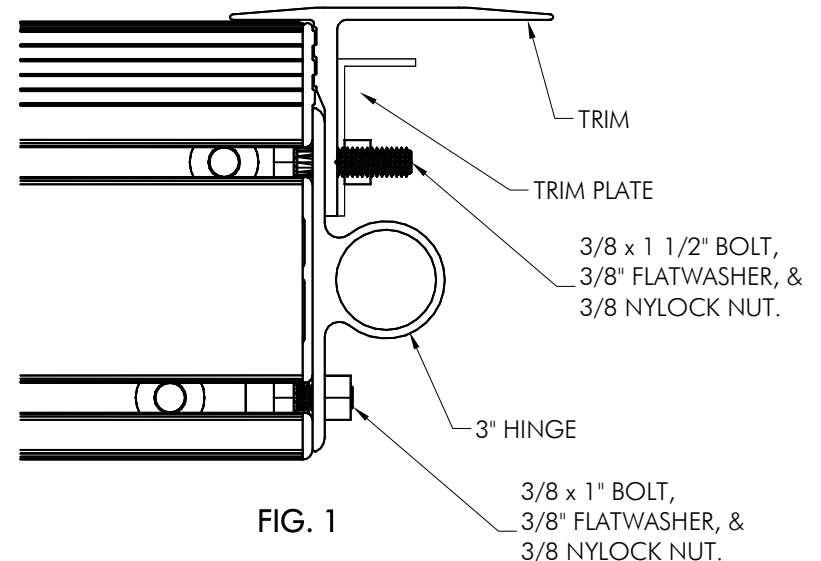

FIG. 1

STEP 2

- LOCATE 3" HINGES AND TORQUE BOLTS TO 40 FT. LBS. SEE FIG. 2

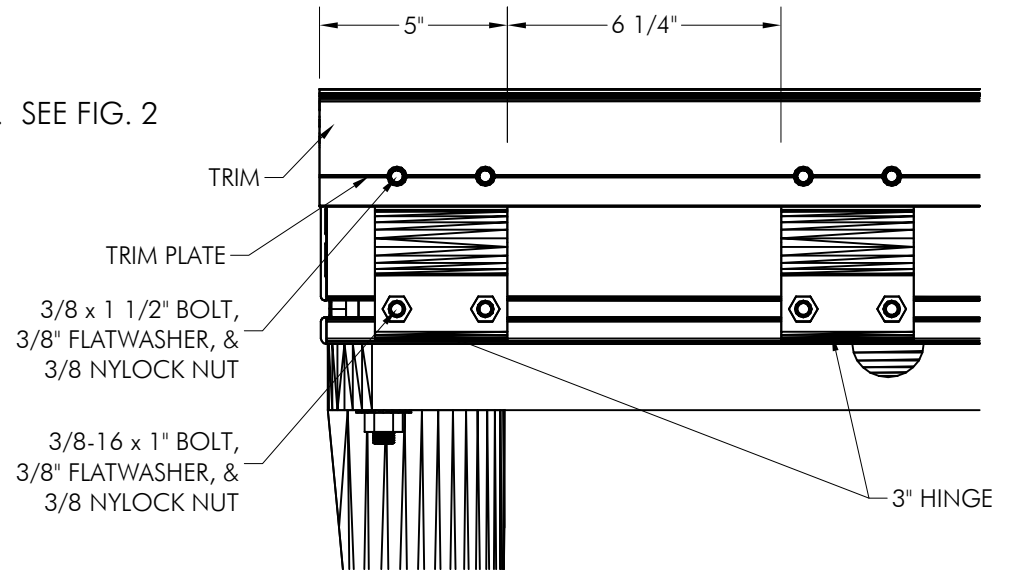

FIG. 2

STEP 3

- POSITION SHORE END RAMP HINGES BETWEEN 3" HINGES AND INSERT HINGE PINS THROUGH HINGES. INSERT 3/8" FLATWASHER AND 3/8" NYLOCK NUT INTO UPPER NUT TRACK AND 3/8" FLATWASHER AND 3/8" NUT INTO LOWER NUT TRACK. PUT (1) 3/8 x 1" BOLT THRU HINGE PLATE AND INTO NYLOCK IN UPPER NUT TRACK. PUT (1) 3/8 x 3/4" BOLT W/ (1) 3/8" FLATWASHER INTO HEX NUT IN LOWER NUT TRACK. POSITION HINGE PLATE OVER HINGE PIN AND TIGHTEN BOLTS IN HINGE PLATE. SEE FIG. 3

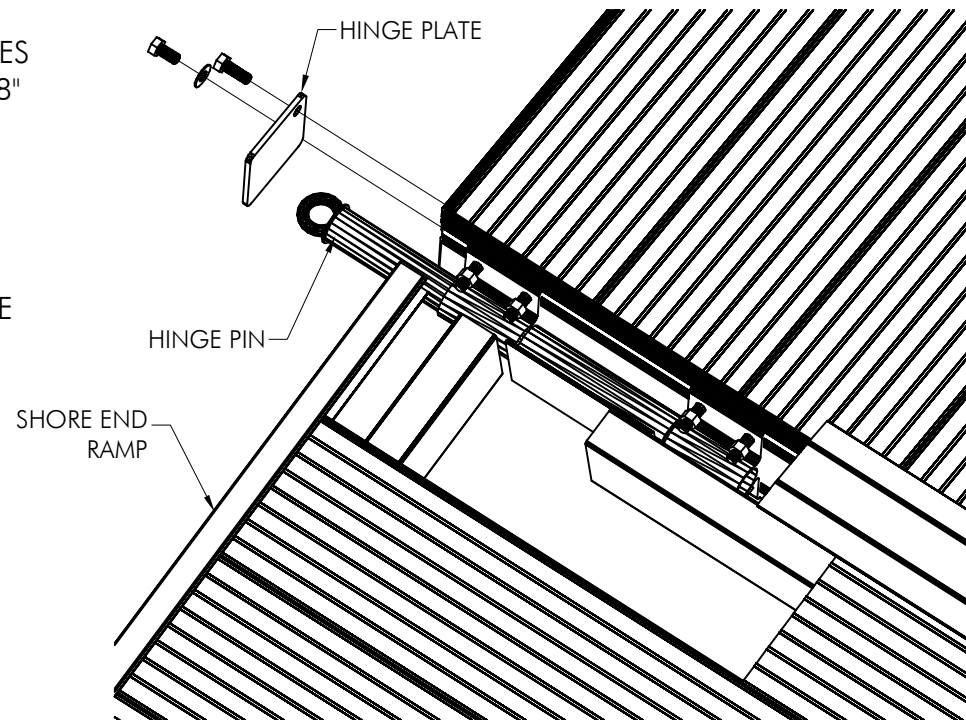

FIG. 3