

# **DOCK BUMPER EDGING**

## **INSTALLATION INSTRUCTIONS**

### **P/N 510-00300-00**

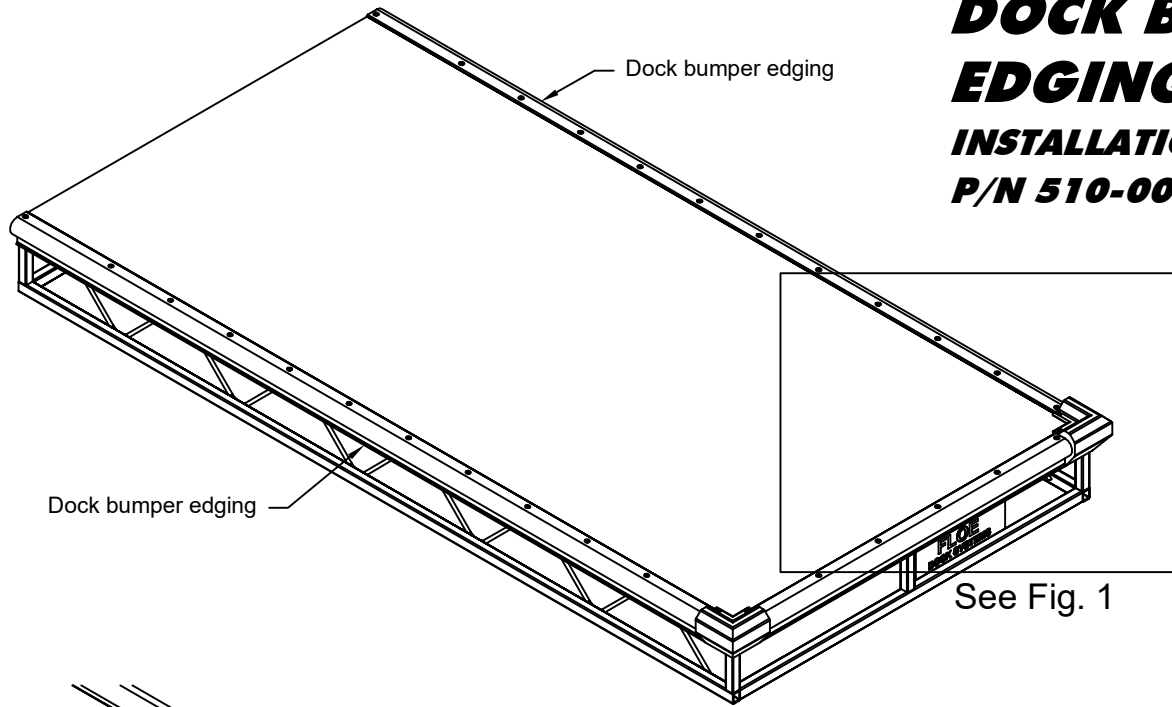

1. Cut bumper edging to desired length and place on dock section.
2. Drill holes for rivets using a #9 drill (.196 dia.). See Fig. 1 below for proper spacing.
3. Rivet bumper edging to dock section using the 3/16" x 1 1/2" SF rivets and washers provided.

Note:

Optional FLOE corner bumpers are recommended on all outside corners (P/N 510-04100-00)

This kit contains:

- (2) 10' long dock bumper edging sections
- (40) 3/16" x 1 1/2" SF rivets
- (40) Backing washers

Tools Required:

- Cordless Drill
- #9 Drill Bit
- Rivet Gun

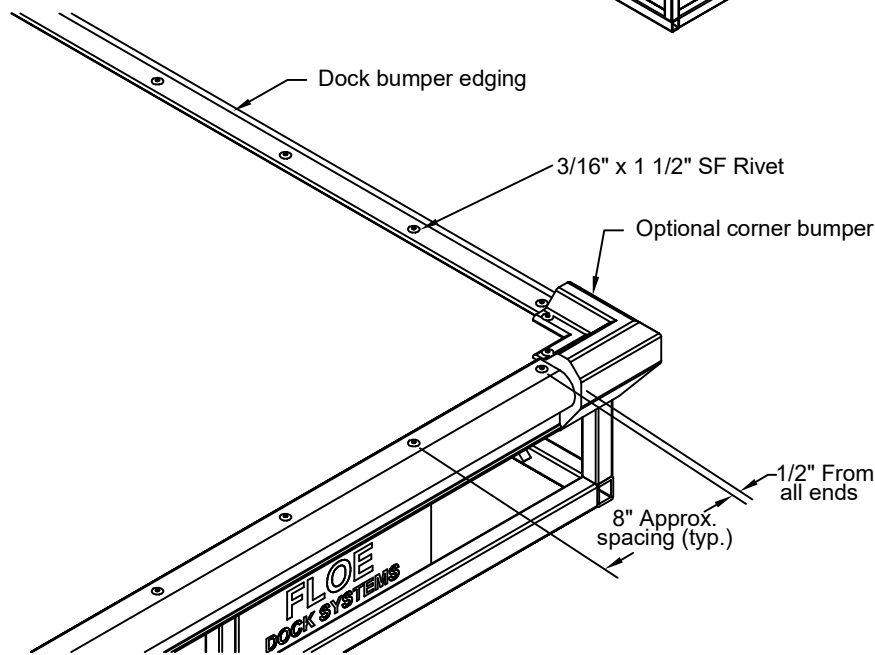

Fig. 1

**WARNING (CORDED DRILLS): TO AVOID ELECTRIC SHOCK DURING DRILLING. USE OF A GROUND FAULT INTERRUPT CIRCUIT IS REQUIRED. FAILURE TO FOLLOW THIS WARNING MAY RESULT IN DEATH BY ELECTROCUTION. DOCK SHOULD BE REMOVED FROM LAKE PRIOR TO DRILLING TO MINIMIZE RISK.**